



# ASZC18 SPLIT SYSTEM HEAT PUMP

**COOLING CAPACITY: 35,000 - 56,500 BTU/H**

**HEATING CAPACITY: 33,600 - 56,400 BTU/H**

**UP TO 18 SEER**

**R-410A**

### Standard Features

- R-410A chlorine-free refrigerant
- Two-Stage Copeland® UltraTech scroll compressor
- High-density foam compressor sound blanket
- ComfortNet™ Communications System compatible
- Expanded ComfortAlert™ diagnostics built in
- Simple low-voltage wiring to outdoor unit in communicating mode
- Diagnostic indicator lights and storage of six fault codes
- Color-coded terminal strip for non-communicating set-up
- SmartShift™ technology with short-cycle protection to ensure quiet, reliable defrost
- Factory-installed bi-flow liquid-line filter drier
- Factory-installed suction-line accumulator
- Factory-installed compressor crankcase heater
- Factory-installed high-capacity muffler
- Factory-installed coil and ambient temperature sensors
- Fully charged for 15' of tubing length
- Quiet ECM-style condenser fan motor
- Sweat connection service valves with easy access to gauge ports
- AHRI Certified; ETL Listed

### Cabinet Features

- Amana® brand sound control top design
- Wire fan discharge grille
- Steel louver coil guard
- Baked-on powder-paint finish
- Rust-resistant coated screws
- Compact footprint
- Top and side maintenance access
- Single panel access to controls with space provided for field-installed accessories
- When properly anchored, meets the 2001 Florida Building Code unit integrity requirements for hurricane-type winds (Anchor bracket kits available.)



### Contents

Nomenclature .....	2
Product Specifications .....	3
Expanded Cooling Data .....	4
Expanded Heating Data .....	16
AHRI Ratings.....	18
Wiring Diagram.....	23
Dimensions .....	24
Accessories .....	24



\* Complete warranty details available from your local dealer or at [www.amana-hac.com](http://www.amana-hac.com). To receive the Lifetime Unit Replacement Limited Warranty (good for as long as you own your home) and 10-Year Parts Limited Warranty, online registration must be completed within 60 days of installation. Online registration is not required in California or Québec.

## NOMENCLATURE

	A	S	Z	C	18	036	1	A	A			
	1	2	3	4	5,6	7,8,9	10	11	12			
<b>Brand</b>	A Amana® Brand							<b>Engineering *</b>				
								Minor Revision				
<b>Product Category</b>	S Split System									<b>Engineering *</b>		
										Major Revision		
<b>Unit Type</b>	X Condenser R-410A			Z Heat Pump R-410A							<b>Electrical</b>	
							1 208/230 V, 1 Phase, 60 Hz					
							2 220/240 V, 1 Phase, 50 Hz					
							3 208/230 V, 3 Phase, 60 Hz					
							4 460 V, 3 Phase, 60 Hz					
<b>Communication Feature</b>	C ComfortNet 4-wire communications ready										<b>Nominal Capacity</b>	
											024 2 Tons 048 4 Tons	
<b>Efficiency</b>	13 13 SEER 16 16 SEER		14 14 SEER 18 18 SEER								036 3 Tons 060 5 Tons	

\* Neither used for order entry or inventory management.



**Important EnergyStar Notice:** EnergyStar ratings are dependent upon conditions beyond equipment installation. Proper sizing and installation of equipment is critical to achieve optimal performance. Split system air conditioners and heat pumps must be matched with appropriate coil components to meet EnergyStar criteria. Ask your contractor for details or visit [www.energystar.gov](http://www.energystar.gov).

## SPECIFICATIONS

	ASZC18 0361A	ASZC18 0481A	ASZC18 0601B
<b>Cooling Capacity</b>			
Nominal Cooling (BTU/h)	35,000	47,000	57,000
Nominal Heating (BTU/h)	35,000	47,000	57,000
Decibels	72	73	75
<b>Compressor</b>			
RLA	16.7	21.2	23.0
LRA	82	96	118
<b>Condenser Fan Motor</b>			
Horsepower (RPM)	½	½	½
FLA	2.8	2.8	2.8
<b>Refrigeration System</b>			
Refrigerant Line Size <sup>1</sup>			
Liquid Line Size ("O.D.)	¾"	¾"	¾"
Suction Line Size ("O.D.)	7⁄8"	1½"	1½"
Refrigerant Connection Size			
Liquid Valve Size ("O.D.)	¾"	¾"	¾"
Suction Valve Size ("O.D.)	7⁄8"	1½"	1½"
Valve Connection Type	Sweat	Sweat	Sweat
Refrigerant Charge	188	278	278
Expansion Device	TXV	TXV	TXV
Superheat at Service Valve	7-9°F	7-9°F	7-9°F
Subcooling at Service Valve			
High Stage	8-10°F	8-10°F	8-10°F
Low Stage	5-7°F	5-7°F	5-7°F
<b>Electrical Data</b>			
Voltage-Phase-Hz	208/230-1-60	208/230-1-60	208/230-1-60
Minimum Circuit Ampacity <sup>2</sup>	23.7	29.3	31.6
Max. Overcurrent Protection <sup>3</sup>	40	50	50
Min / Max Volts	197 / 253	197 / 253	197 / 253
Electrical Conduit Size	½" or ¾"	½" or ¾"	½" or ¾"
<b>Ship Weight (lbs)</b>	293	340	360

<sup>1</sup> Tested and rated in accordance with AHRI Standard 210/240

<sup>2</sup> Wire size should be determined in accordance with National Electrical Codes; extensive wire runs will require larger wire sizes

<sup>3</sup> Must use time-delay fuses or HACR-type circuit breakers of the same size as noted.

### NOTES

- Always check the rating plate for electrical data on the unit being installed.
- Installer will need to supply ¾" to 1½" adapters for suction line connections.
- Unit is charged with refrigerant for 15' of ¾" liquid line. System charge must be adjusted per Installation Instructions Final Charge Procedure.
- Installation of these units requires the specified TXV Kit to be installed on the indoor coil. THE SPECIFIED TXV IS DETERMINED BY THE OUT-DOOR UNIT, NOT THE INDOOR COIL.

EXPANDED COOLING DATA — ASZC180361A\*/CA\*F3743\*6\*\* + TXV/MBVC1600\*\* — LOW STAGE

IDB	AIRFLOW	OUTDOOR AMBIENT TEMPERATURE												ENTERING INDOOR WET BULB TEMPERATURE													
		65°F				75°F				85°F				95°F				105°F				115°F					
		59	63	67	71	59	63	67	71	59	63	67	71	59	63	67	71	59	63	67	71	59	63	67	71		
70	956	MBh	24.8	25.7	28.1	-	24.2	25.1	27.5	-	23.6	24.5	26.8	-	23.1	23.9	26.2	-	21.9	22.7	24.9	-	20.3	21.0	23.0	-	
		S/T	0.77	0.64	0.44	-	0.79	0.66	0.46	-	0.81	0.68	0.47	-	0.84	0.70	0.49	-	0.87	0.73	0.50	-	0.88	0.73	0.51	-	
	850	ΔT	18	16	12	-	18	16	12	-	18	16	12	-	19	16	12	-	18	16	12	-	17	15	11	-	
		kW	1.34	1.37	1.42	-	1.45	1.48	1.54	-	1.55	1.58	1.64	-	1.63	1.67	1.73	-	1.71	1.75	1.81	-	1.77	1.81	1.88	-	
	744	Amps	5.3	5.4	5.6	-	5.7	5.9	6.1	-	6.2	6.4	6.6	-	6.7	6.8	7.1	-	7.1	7.3	7.5	-	7.5	7.7	8.0	-	
		Hi PR	209	225	237	-	234	252	266	-	267	287	303	-	304	327	345	-	342	368	388	-	377	406	429	-	
	75	956	Lo PR	111	118	128	-	117	124	136	-	121	129	141	-	128	136	148	-	134	142	155	-	138	147	161	-
			MBh	24.1	24.9	27.3	-	23.5	24.4	26.7	-	22.9	23.8	26.1	-	22.4	23.2	25.4	-	21.3	22.0	24.1	-	19.7	20.4	22.4	-
		850	S/T	0.73	0.61	0.42	-	0.76	0.63	0.44	-	0.78	0.65	0.45	-	0.80	0.67	0.46	-	0.83	0.69	0.48	-	0.84	0.70	0.48	-
			ΔT	19	16	12	-	19	17	13	-	19	17	13	-	19	17	13	-	19	17	13	-	18	15	12	-
744		kW	1.33	1.36	1.40	-	1.44	1.47	1.52	-	1.54	1.57	1.63	-	1.62	1.66	1.72	-	1.69	1.73	1.79	-	1.76	1.80	1.86	-	
		Amps	5.3	5.4	5.6	-	5.7	5.8	6.0	-	6.2	6.3	6.5	-	6.6	6.8	7.0	-	7.0	7.2	7.5	-	7.5	7.6	7.9	-	
70		Hi PR	207	223	235	-	232	250	264	-	264	284	300	-	301	324	342	-	338	364	384	-	374	402	425	-	
		Lo PR	110	117	127	-	116	123	134	-	120	128	140	-	126	134	147	-	132	141	154	-	137	146	159	-	
75		956	MBh	22.2	23.0	25.2	-	21.7	22.5	24.6	-	21.2	21.9	24.0	-	20.7	21.4	23.5	-	19.6	20.3	22.3	-	18.2	18.8	20.6	-
			S/T	0.70	0.59	0.41	-	0.73	0.61	0.42	-	0.75	0.62	0.43	-	0.77	0.64	0.45	-	0.80	0.67	0.46	-	0.81	0.67	0.47	-
	850	ΔT	19	17	13	-	20	17	13	-	20	17	13	-	20	17	13	-	19	17	13	-	18	16	12	-	
		kW	1.29	1.32	1.37	-	1.40	1.43	1.48	-	1.50	1.53	1.58	-	1.58	1.61	1.67	-	1.65	1.69	1.75	-	1.71	1.75	1.81	-	
	744	Amps	5.1	5.2	5.4	-	5.5	5.7	5.9	-	6.0	6.2	6.4	-	6.4	6.6	6.8	-	6.8	7.0	7.2	-	7.2	7.4	7.7	-	
		Hi PR	201	216	228	-	225	242	256	-	256	276	291	-	292	314	331	-	328	353	373	-	363	390	412	-	
	75	956	Lo PR	106	113	123	-	112	119	130	-	117	124	135	-	123	130	142	-	128	137	149	-	133	141	154	-
			MBh	25.2	25.9	28.1	30.1	24.6	25.3	27.4	29.4	24.0	24.7	26.8	28.7	23.4	24.1	26.1	28.0	22.3	22.9	24.8	26.6	20.6	21.2	23.0	24.7
		850	S/T	0.87	0.78	0.59	0.38	0.90	0.81	0.61	0.39	0.92	0.83	0.63	0.40	0.95	0.85	0.65	0.42	0.99	0.89	0.67	0.43	1.00	0.89	0.68	0.44
			ΔT	21	19	16	11	21	20	16	11	21	20	16	11	22	20	16	11	21	20	16	11	20	18	15	10
70		kW	1.35	1.38	1.43	1.48	1.46	1.50	1.55	1.60	1.56	1.60	1.65	1.71	1.65	1.69	1.75	1.81	1.72	1.76	1.83	1.89	1.79	1.83	1.89	1.96	
		Amps	5.4	5.5	5.7	5.9	5.8	5.9	6.1	6.4	6.3	6.5	6.7	6.9	6.7	6.9	7.1	7.4	7.2	7.3	7.6	7.9	7.6	7.8	8.0	8.4	
75		Hi PR	211	227	240	250	237	255	269	281	269	290	306	319	307	330	349	364	345	371	392	409	381	410	433	452	
		Lo PR	112	119	130	138	118	126	137	146	123	131	143	152	129	137	150	159	135	144	157	167	140	149	162	173	
75		956	MBh	24.5	25.2	27.3	29.3	23.9	24.6	26.6	28.6	23.3	24.0	26.0	27.9	22.8	23.4	25.4	27.2	21.6	22.3	24.1	25.9	20.0	20.6	22.3	24.0
			S/T	0.83	0.74	0.56	0.36	0.86	0.77	0.58	0.37	0.88	0.79	0.60	0.38	0.91	0.81	0.62	0.40	0.94	0.85	0.64	0.41	0.95	0.85	0.64	0.41
	850	ΔT	22	20	17	11	22	20	17	12	22	20	17	12	22	21	17	12	22	20	17	12	21	19	16	11	
		kW	1.34	1.37	1.42	1.47	1.45	1.48	1.54	1.59	1.55	1.59	1.64	1.70	1.64	1.67	1.73	1.79	1.71	1.75	1.81	1.87	1.77	1.81	1.88	1.95	
	70	Amps	5.3	5.4	5.6	5.8	5.7	5.9	6.1	6.3	6.2	6.4	6.6	6.9	6.7	6.8	7.1	7.3	7.1	7.3	7.5	7.8	7.5	7.7	8.0	8.3	
		Hi PR	209	225	237	248	234	252	266	278	267	287	303	316	304	327	345	360	342	368	388	405	378	406	429	447	
	75	Lo PR	111	118	128	137	117	124	136	145	121	129	141	150	128	136	148	158	134	142	155	165	138	147	161	171	
		MBh	22.6	23.3	25.2	27.0	22.1	22.7	24.6	26.4	21.5	22.2	24.0	25.8	21.0	21.6	23.4	25.1	20.0	20.5	22.2	23.9	18.5	19.0	20.6	22.1	
	75	956	S/T	0.80	0.72	0.54	0.35	0.83	0.74	0.56	0.36	0.85	0.76	0.58	0.37	0.88	0.79	0.59	0.38	0.91	0.81	0.62	0.40	0.92	0.82	0.62	0.40
			ΔT	22	21	17	12	23	21	17	12	23	21	17	12	23	21	17	12	22	21	17	12	21	19	16	11
850		kW	1.31	1.34	1.38	1.43	1.41	1.45	1.50	1.55	1.51	1.54	1.60	1.65	1.59	1.63	1.69	1.75	1.66	1.70	1.76	1.82	1.72	1.77	1.83	1.89	
		Amps	5.2	5.3	5.5	5.7	5.6	5.7	5.9	6.1	6.1	6.2	6.4	6.7	6.5	6.6	6.9	7.1	6.9	7.1	7.3	7.6	7.3	7.5	7.7	8.0	
70		Hi PR	203	218	230	240	227	245	258	270	259	278	294	307	295	317	335	349	331	357	377	393	366	394	416	434	
		Lo PR	107	114	125	133	113	121	132	140	118	125	137	146	124	132	144	153	130	138	151	160	134	143	156	166	

kW = Total system power  
Amps = outdoor unit amps (compressor + fan)

Shaded area reflects ACCA (TVA) conditions

IDB: Entering Indoor Dry Bulb Temperature  
High and low pressures are measured at the liquid and suction service valves.

EXPANDED COOLING DATA — ASZC180361A\*/CA\*F3743\*6\*\* + TXV/MBVC1600\*\* — LOW STAGE (CONT.)

IDB	AIRFLOW	OUTDOOR AMBIENT TEMPERATURE												ENTERING INDOOR WET BULB TEMPERATURE											
		65°F				75°F				85°F				95°F				105°F				115°F			
		59	63	67	71	59	63	67	71	59	63	67	71	59	63	67	71	59	63	67	71	59	63	67	71
956	MBh	25.7	26.2	28.0	29.9	25.1	25.6	27.4	29.2	24.5	25.0	26.7	28.5	23.9	24.4	26.0	27.8	22.7	23.2	24.7	26.5	21.0	21.5	22.9	24.5
	S/T	0.95	0.90	0.73	0.54	1.00	0.93	0.75	0.56	1.00	0.95	0.77	0.58	1.00	1.00	0.80	0.60	1.00	1.00	0.83	0.62	1.00	1.00	0.84	0.63
	ΔT	24	23	20	16	24	23	20	16	23	23	20	16	22	22	20	16	22	22	20	16	20	21	18	15
	kW	1.36	1.39	1.44	1.49	1.48	1.51	1.56	1.62	1.58	1.61	1.67	1.73	1.66	1.70	1.76	1.83	1.74	1.78	1.84	1.91	1.80	1.85	1.91	1.98
	Amps	5.4	5.5	5.7	5.9	5.9	6.0	6.2	6.4	6.4	6.5	6.7	7.0	6.8	7.0	7.2	7.5	7.2	7.4	7.7	8.0	7.7	7.9	8.1	8.4
	Hi PR	213	229	242	253	239	257	272	284	272	293	309	322	310	333	352	367	349	375	396	413	385	415	438	457
Lo PR	113	120	131	140	119	127	138	147	124	132	144	153	130	138	151	161	136	145	158	169	141	150	164	175	
850	MBh	24.9	25.4	27.2	29.1	24.3	24.9	26.6	28.4	23.7	24.3	25.9	27.7	23.2	23.7	25.3	27.0	22.0	22.5	24.0	25.7	20.4	20.8	22.3	23.8
	S/T	0.91	0.85	0.69	0.52	0.94	0.88	0.72	0.54	0.97	0.91	0.74	0.55	1.00	0.94	0.76	0.57	1.00	0.97	0.79	0.59	1.00	0.98	0.80	0.60
	ΔT	25	23	20	16	25	24	21	17	25	24	21	17	25	24	21	17	24	24	21	16	22	22	19	15
	kW	1.35	1.38	1.43	1.48	1.46	1.50	1.55	1.60	1.56	1.60	1.65	1.71	1.65	1.69	1.75	1.81	1.72	1.76	1.83	1.89	1.79	1.83	1.89	1.96
	Amps	5.4	5.5	5.7	5.9	5.8	5.9	6.1	6.4	6.3	6.5	6.7	6.9	6.7	6.9	7.1	7.4	7.2	7.3	7.6	7.9	7.6	7.8	8.0	8.4
	Hi PR	211	227	240	250	237	255	269	281	269	290	306	319	307	330	349	364	345	371	392	409	381	410	433	452
Lo PR	112	119	130	138	118	126	137	146	123	131	143	152	129	137	150	159	135	144	157	167	140	149	162	173	
744	MBh	23.0	23.5	25.1	26.8	22.5	22.9	24.5	26.2	21.9	22.4	23.9	25.6	21.4	21.8	23.3	25.0	20.3	20.8	22.2	23.7	18.8	19.2	20.5	22.0
	S/T	0.88	0.82	0.67	0.50	0.91	0.85	0.69	0.52	0.93	0.87	0.71	0.53	0.96	0.90	0.73	0.55	1.00	0.94	0.76	0.57	1.01	0.94	0.77	0.57
	ΔT	25	24	21	17	25	24	21	17	25	24	21	17	25	24	21	17	25	24	21	17	23	22	20	16
	kW	1.32	1.35	1.39	1.44	1.43	1.46	1.51	1.56	1.52	1.56	1.61	1.67	1.61	1.64	1.70	1.76	1.68	1.72	1.78	1.84	1.74	1.78	1.84	1.91
	Amps	5.2	5.3	5.5	5.7	5.6	5.8	6.0	6.2	6.1	6.3	6.5	6.7	6.5	6.7	6.9	7.2	7.0	7.1	7.4	7.7	7.4	7.6	7.8	8.1
	Hi PR	205	220	233	243	230	247	261	272	261	281	297	310	298	320	338	353	335	360	380	397	370	398	420	438
Lo PR	108	115	126	134	115	122	133	142	119	127	138	147	125	133	145	155	131	139	152	162	136	144	157	168	

956	MBh	26.1	26.6	27.9	29.7	25.5	26.0	27.2	29.0	24.9	25.4	26.6	28.3	24.3	24.7	25.9	27.7	23.1	23.5	24.6	26.3	21.4	21.8	22.8	24.3
	S/T	1.00	0.97	0.87	0.71	1.00	1.00	0.90	0.73	1.00	1.00	0.93	0.75	1.00	1.00	0.96	0.78	1.00	1.00	0.99	0.80	1.00	1.00	1.00	0.81
	ΔT	25	25	23	20	25	25	24	20	24	24	24	20	23	24	24	21	22	23	23	20	21	21	22	19
	kW	1.38	1.41	1.45	1.50	1.49	1.52	1.58	1.63	1.59	1.63	1.68	1.74	1.68	1.72	1.78	1.84	1.75	1.80	1.86	1.93	1.82	1.86	1.93	2.00
	Amps	5.5	5.6	5.8	6.0	5.9	6.0	6.2	6.5	6.4	6.6	6.8	7.0	6.9	7.0	7.3	7.5	7.3	7.5	7.7	8.0	7.7	7.9	8.2	8.5
	Hi PR	215	232	245	255	242	260	275	286	275	296	312	326	313	337	356	371	352	379	400	417	389	419	442	461
Lo PR	114	121	132	141	120	128	140	149	125	133	145	155	131	140	153	163	138	147	160	170	143	152	166	176	
850	MBh	25.3	25.8	27.1	28.9	24.7	25.2	26.4	28.2	24.2	24.6	25.8	27.5	23.6	24.0	25.2	26.8	22.4	22.8	23.9	25.5	20.7	21.1	22.1	23.6
	S/T	0.95	0.92	0.83	0.67	0.99	0.95	0.86	0.70	1.00	0.98	0.88	0.72	1.00	1.00	0.91	0.74	1.00	1.00	0.95	0.77	1.00	1.00	0.95	0.77
	ΔT	26	26	24	21	26	26	25	21	26	26	25	21	25	26	25	21	24	25	24	21	22	22	23	20
	kW	1.36	1.39	1.44	1.49	1.48	1.51	1.56	1.62	1.58	1.61	1.67	1.73	1.66	1.70	1.76	1.83	1.74	1.78	1.84	1.91	1.80	1.85	1.91	1.98
	Amps	5.4	5.5	5.7	5.9	5.9	6.0	6.2	6.4	6.4	6.5	6.7	7.0	6.8	7.0	7.2	7.5	7.2	7.4	7.7	8.0	7.7	7.9	8.1	8.4
	Hi PR	213	229	242	253	239	257	272	284	272	293	309	322	310	333	352	367	349	375	396	413	385	415	438	457
Lo PR	113	120	131	140	119	127	138	147	124	132	144	153	130	138	151	161	136	145	158	169	141	150	164	175	
744	MBh	23.4	23.8	25.0	26.6	22.8	23.3	24.4	26.0	22.3	22.7	23.8	25.4	21.8	22.2	23.2	24.8	20.7	21.1	22.1	23.5	19.1	19.5	20.4	21.8
	S/T	0.92	0.89	0.80	0.65	0.95	0.92	0.83	0.67	0.98	0.94	0.85	0.69	1.00	0.97	0.88	0.71	1.00	1.00	0.91	0.74	1.00	1.00	0.92	0.75
	ΔT	26.6	26	25	21	27	26	25	22	27	27	25	22	27	27	25	22	26	26	25	22	24	24	23	20
	kW	1.33	1.36	1.40	1.45	1.44	1.47	1.52	1.57	1.53	1.57	1.62	1.68	1.62	1.66	1.72	1.78	1.69	1.73	1.79	1.86	1.76	1.80	1.86	1.93
	Amps	5.3	5.4	5.6	5.8	5.7	5.8	6.0	6.2	6.2	6.3	6.5	6.8	6.6	6.8	7.0	7.3	7.0	7.2	7.4	7.7	7.5	7.6	7.9	8.2
	Hi PR	207	223	235	245	232	250	264	275	264	284	300	313	301	323	342	356	338	364	384	401	374	402	425	443
Lo PR	109	116	127	135	116	123	134	143	120	128	140	149	126	134	147	156	132	141	154	164	137	146	159	169	

kW = Total system power  
Amps = outdoor unit amps (compressor + fan)

Shaded area reflects AHRI (TVA) conditions

IDB: Entering Indoor Dry Bulb Temperature  
High and low pressures are measured at the liquid and suction service valves.

EXPANDED COOLING DATA — ASZC180361A\*/CA\*F3743\*6\*\* + TXV/MBVC1600\*\* — HIGH STAGE

IDB	AIRFLOW	OUTDOOR AMBIENT TEMPERATURE												ENTERING INDOOR WET BULB TEMPERATURE													
		65°F				75°F				85°F				95°F				105°F				115°F					
		59	63	67	71	59	63	67	71	59	63	67	71	59	63	67	71	59	63	67	71	59	63	67	71		
70	1406	MBh	34.5	35.8	39.2	-	33.7	34.9	38.3	-	32.9	34.1	37.4	-	32.1	33.3	36.5	-	30.5	31.6	34.6	-	28.3	29.3	32.1	-	
		S/T	0.76	0.63	0.44	-	0.79	0.66	0.45	-	0.81	0.67	0.47	-	0.83	0.70	0.48	-	0.86	0.72	0.50	-	0.87	0.73	0.50	-	
	ΔT	17	15	11	-	17	15	11	-	17	15	11	-	17	15	11	-	17	15	11	-	16	14	11	-		
	1250	kW	2.10	2.14	2.21	-	2.26	2.31	2.39	-	2.41	2.47	2.55	-	2.54	2.60	2.69	-	2.65	2.71	2.81	-	2.75	2.81	2.91	-	
		Amps	7.8	8.0	8.2	-	8.4	8.6	8.9	-	9.2	9.4	9.7	-	9.8	10.1	10.4	-	10.5	10.7	11.1	-	11.1	11.4	11.8	-	
	1094	MBh	33.5	34.7	38.1	-	32.7	33.9	37.2	-	32.0	33.1	36.3	-	31.2	32.3	35.4	-	29.6	30.7	33.6	-	27.4	28.4	31.2	-	
		S/T	0.72	0.60	0.42	-	0.75	0.63	0.43	-	0.77	0.64	0.44	-	0.79	0.66	0.46	-	0.82	0.69	0.48	-	0.83	0.69	0.48	-	
	75	1406	MBh	35.1	36.1	39.1	42.0	34.3	35.3	38.2	41.0	33.5	34.5	37.3	40.0	32.7	33.6	36.4	39.1	31.0	31.9	34.6	37.1	28.7	29.6	32.0	34.4
			S/T	0.86	0.77	0.58	0.38	0.89	0.80	0.60	0.39	0.92	0.82	0.62	0.40	0.95	0.85	0.64	0.41	0.98	0.88	0.66	0.43	0.99	0.89	0.67	0.43
		ΔT	20	18	15	10	20	18	15	10	20	18	15	10	20	19	15	11	20	18	15	10	19	17	14	10	
1250		kW	2.11	2.16	2.23	2.31	2.28	2.33	2.41	2.49	2.43	2.49	2.57	2.66	2.56	2.62	2.71	2.81	2.68	2.74	2.83	2.93	2.77	2.84	2.94	3.04	
		Amps	7.8	8.0	8.3	8.6	8.5	8.7	9.0	9.3	9.2	9.5	9.8	10.2	9.9	10.2	10.5	10.9	10.6	10.8	11.2	11.6	11.2	11.5	11.9	12.3	
1094		MBh	34.1	35.1	38.0	40.8	33.3	34.3	37.1	39.8	32.5	33.5	36.2	38.9	31.7	32.6	35.3	37.9	30.1	31.0	33.6	36.0	27.9	28.7	31.1	33.4	
		S/T	0.82	0.74	0.56	0.36	0.85	0.76	0.58	0.37	0.87	0.78	0.59	0.38	0.90	0.81	0.61	0.39	0.94	0.84	0.63	0.41	0.94	0.84	0.64	0.41	
70		1406	MBh	34.5	35.8	39.2	-	33.7	34.9	38.3	-	32.9	34.1	37.4	-	32.1	33.3	36.5	-	30.5	31.6	34.6	-	28.3	29.3	32.1	-
			S/T	0.76	0.63	0.44	-	0.79	0.66	0.45	-	0.81	0.67	0.47	-	0.83	0.70	0.48	-	0.86	0.72	0.50	-	0.87	0.73	0.50	-
		ΔT	17	15	11	-	17	15	11	-	17	15	11	-	17	15	11	-	17	15	11	-	16	14	11	-	
	1250	kW	2.10	2.14	2.21	-	2.26	2.31	2.39	-	2.41	2.47	2.55	-	2.54	2.60	2.69	-	2.65	2.71	2.81	-	2.75	2.81	2.91	-	
		Amps	7.8	8.0	8.2	-	8.4	8.6	8.9	-	9.2	9.4	9.7	-	9.8	10.1	10.4	-	10.5	10.7	11.1	-	11.1	11.4	11.8	-	
	1094	MBh	33.5	34.7	38.1	-	32.7	33.9	37.2	-	32.0	33.1	36.3	-	31.2	32.3	35.4	-	29.6	30.7	33.6	-	27.4	28.4	31.2	-	
		S/T	0.72	0.60	0.42	-	0.75	0.63	0.43	-	0.77	0.64	0.44	-	0.79	0.66	0.46	-	0.82	0.69	0.48	-	0.83	0.69	0.48	-	
	75	1406	MBh	35.1	36.1	39.1	42.0	34.3	35.3	38.2	41.0	33.5	34.5	37.3	40.0	32.7	33.6	36.4	39.1	31.0	31.9	34.6	37.1	28.7	29.6	32.0	34.4
			S/T	0.86	0.77	0.58	0.38	0.89	0.80	0.60	0.39	0.92	0.82	0.62	0.40	0.95	0.85	0.64	0.41	0.98	0.88	0.66	0.43	0.99	0.89	0.67	0.43
		ΔT	20	18	15	10	20	18	15	10	20	18	15	10	20	19	15	11	20	18	15	10	19	17	14	10	
1250		kW	2.11	2.16	2.23	2.31	2.28	2.33	2.41	2.49	2.43	2.49	2.57	2.66	2.56	2.62	2.71	2.81	2.68	2.74	2.83	2.93	2.77	2.84	2.94	3.04	
		Amps	7.8	8.0	8.3	8.6	8.5	8.7	9.0	9.3	9.2	9.5	9.8	10.2	9.9	10.2	10.5	10.9	10.6	10.8	11.2	11.6	11.2	11.5	11.9	12.3	
1094		MBh	34.1	35.1	38.0	40.8	33.3	34.3	37.1	39.8	32.5	33.5	36.2	38.9	31.7	32.6	35.3	37.9	30.1	31.0	33.6	36.0	27.9	28.7	31.1	33.4	
		S/T	0.82	0.74	0.56	0.36	0.85	0.76	0.58	0.37	0.87	0.78	0.59	0.38	0.90	0.81	0.61	0.39	0.94	0.84	0.63	0.41	0.94	0.84	0.64	0.41	
70		1406	MBh	34.5	35.8	39.2	-	33.7	34.9	38.3	-	32.9	34.1	37.4	-	32.1	33.3	36.5	-	30.5	31.6	34.6	-	28.3	29.3	32.1	-
			S/T	0.76	0.63	0.44	-	0.79	0.66	0.45	-	0.81	0.67	0.47	-	0.83	0.70	0.48	-	0.86	0.72	0.50	-	0.87	0.73	0.50	-
		ΔT	17	15	11	-	17	15	11	-	17	15	11	-	17	15	11	-	17	15	11	-	16	14	11	-	
	1250	kW	2.10	2.14	2.21	-	2.26	2.31	2.39	-	2.41	2.47	2.55	-	2.54	2.60	2.69	-	2.65	2.71	2.81	-	2.75	2.81	2.91	-	
		Amps	7.8	8.0	8.2	-	8.4	8.6	8.9	-	9.2	9.4	9.7	-	9.8	10.1	10.4	-	10.5	10.7	11.1	-	11.1	11.4	11.8	-	
	1094	MBh	33.5	34.7	38.1	-	32.7	33.9	37.2	-	32.0	33.1	36.3	-	31.2	32.3	35.4	-	29.6	30.7	33.6	-	27.4	28.4	31.2	-	
		S/T	0.72	0.60	0.42	-	0.75	0.63	0.43	-	0.77	0.64	0.44	-	0.79	0.66	0.46	-	0.82	0.69	0.48	-	0.83	0.69	0.48	-	
	75	1406	MBh	35.1	36.1	39.1	42.0	34.3	35.3	38.2	41.0	33.5	34.5	37.3	40.0	32.7	33.6	36.4	39.1	31.0	31.9	34.6	37.1	28.7	29.6	32.0	34.4
			S/T	0.86	0.77	0.58	0.38	0.89	0.80	0.60	0.39	0.92	0.82	0.62	0.40	0.95	0.85	0.64	0.41	0.98	0.88	0.66	0.43	0.99	0.89	0.67	0.43
		ΔT	20	18	15	10	20	18	15	10	20	18	15	10	20	19	15	11	20	18	15	10	19	17	14	10	
1250		kW	2.11	2.16	2.23	2.31	2.28	2.33	2.41	2.49	2.43	2.49	2.57	2.66	2.56	2.62	2.71	2.81	2.68	2.74	2.83	2.93	2.77	2.84	2.94	3.04	
		Amps	7.8	8.0	8.3	8.6	8.5	8.7	9.0	9.3	9.2	9.5	9.8	10.2	9.9	10.2	10.5	10.9	10.6	10.8	11.2	11.6	11.2	11.5	11.9	12.3	
1094		MBh	34.1	35.1	38.0	40.8	33.3	34.3	37.1	39.8	32.5	33.5	36.2	38.9	31.7	32.6	35.3	37.9	30.1	31.0	33.6	36.0	27.9	28.7	31.1	33.4	
		S/T	0.82	0.74	0.56	0.36	0.85	0.76	0.58	0.37	0.87	0.78	0.59	0.38	0.90	0.81	0.61	0.39	0.94	0.84	0.63	0.41	0.94	0.84	0.64	0.41	
70		1406	MBh	34.5	35.8	39.2	-	33.7	34.9	38.3	-	32.9	34.1	37.4	-	32.1	33.3	36.5	-	30.5	31.6	34.6	-	28.3	29.3	32.1	-
			S/T	0.76	0.63	0.44	-	0.79	0.66	0.45	-	0.81	0.67	0.47	-	0.83	0.70	0.48	-	0.86	0.72	0.50	-	0.87	0.73	0.50	-
		ΔT	17	15	11	-	17	15	11	-	17	15	11	-	17	15	11	-	17	15	11	-	16	14	11	-	
	1250	kW	2.10	2.14	2.21	-	2.26	2.31	2.39	-	2.41	2.47	2.55	-	2.54	2.60	2.69	-	2.65	2.71	2.81	-	2.75	2.81	2.91	-	
		Amps	7.8	8.0	8.2	-	8.4	8.6	8.9	-	9.2	9.4	9.7	-	9.8	10.1	10.4	-	10.5	10.7	11.1	-	11.1	11.4	11.8	-	
	1094	MBh	33.5	34.7	38.1	-	32.7	33.9	37.2	-	32.0	33.1	36.3	-	31.2	32.3	35.4	-	29.6	30.7	33.6	-	27.4	28.4	31.2	-	
		S/T	0.72	0.60	0.42	-	0.75	0.63	0.43	-	0.77	0.64	0.44	-	0.79	0.66	0.46	-	0.82	0.69	0.48	-	0.83	0.69	0.48	-	
	75	1406	MBh	35.1	36.1	39.1	42.0	34.3	35.3	38.2	41.0	33.5	34.5	37.3	40.0	32.7	33.6	36.4	39.1	31.0	31.9	34.6	37.1	28.7	29.6	32.0	34.4
			S/T	0.86	0.77	0.58	0.38	0.89	0.80	0.60	0.39	0.92	0.82	0.62	0.40	0.95	0.85	0.64	0.41	0.98	0.88	0.66	0.43	0.99	0.89	0.67	0.43
		ΔT	20	18	15	10	20	18	15	10	20	18	15	10	20	19	15	11	20	18	15	10	19	17	14	10	
1250		kW	2.11	2.16	2.23	2.31	2.28	2.33	2.41	2.49	2.43	2.49	2.57	2.66	2.56	2.62	2.71	2.81	2.68	2.74	2.83	2.93	2.77	2.84	2.94	3.04	
		Amps	7.8	8.0	8.3	8.6																					

EXPANDED COOLING DATA — ASZC180361A\*/CA\*F3743\*6\*\* + TXV/MBVC1600\*\* — HIGH STAGE (CONT.)

IDB	AIRFLOW	OUTDOOR AMBIENT TEMPERATURE												ENTERING INDOOR WET BULB TEMPERATURE												
		65°F				75°F				85°F				95°F				105°F				115°F				
		59	63	67	71	59	63	67	71	59	63	67	71	59	63	67	71	59	63	67	71	59	63	67	71	
80	1406	MBh	35.7	36.5	39.0	41.7	34.9	35.7	38.1	40.7	34.1	34.8	37.2	39.8	33.2	34.0	36.3	38.8	31.6	32.3	34.5	36.8	29.2	29.9	31.9	34.1
		S/T	0.95	0.89	0.72	0.54	1.00	0.92	0.75	0.56	1.00	0.94	0.77	0.57	1.00	1.00	0.79	0.59	1.00	1.00	0.82	0.61	1.00	1.00	0.83	0.62
	ΔT	22	21	18	15	23	21	19	15	22	22	19	15	22	22	19	15	21	21	19	15	19	20	17	14	
	kW	2.13	2.18	2.25	2.33	2.30	2.35	2.43	2.52	2.45	2.51	2.59	2.68	2.59	2.65	2.74	2.83	2.70	2.76	2.86	2.96	2.80	2.86	2.96	3.07	
	Amps	7.9	8.1	8.4	8.7	8.6	8.8	9.1	9.4	9.3	9.6	9.9	10.3	10.0	10.2	10.6	11.0	10.7	10.9	11.3	11.7	11.3	11.6	12.0	12.5	
	Hi PR	223	240	254	265	250	269	285	297	285	306	324	338	324	349	369	384	365	393	415	433	403	434	458	478	
	Lo PR	109	116	127	135	115	123	134	143	120	127	139	148	126	134	146	156	132	140	153	163	136	145	158	169	
	MBh	34.7	35.4	37.9	40.5	33.9	34.6	37.0	39.5	33.1	33.8	36.1	38.6	32.3	33.0	35.2	37.7	30.7	31.3	33.5	35.8	28.4	29.0	31.0	33.1	
	S/T	0.90	0.85	0.69	0.51	0.93	0.88	0.71	0.53	0.96	0.90	0.73	0.55	0.99	0.93	0.76	0.56	1.00	0.96	0.78	0.59	1.00	0.97	0.79	0.59	
	ΔT	23	22	19	15	23	22	19	16	23	22	19	16	23	23	20	16	23	22	19	15	21	21	18	14	
kW	2.11	2.16	2.23	2.31	2.28	2.33	2.41	2.49	2.43	2.49	2.57	2.66	2.57	2.62	2.71	2.81	2.68	2.74	2.83	2.93	2.77	2.84	2.94	3.04		
Amps	7.8	8.0	8.3	8.6	8.5	8.7	9.0	9.3	9.2	9.5	9.8	10.2	9.9	10.2	10.5	10.9	10.6	10.8	11.2	11.6	11.2	11.5	11.9	12.3		
Hi PR	221	238	251	262	248	267	282	294	282	303	320	334	321	346	365	381	361	389	411	428	399	430	454	473		
Lo PR	108	115	125	134	114	121	133	141	119	126	138	147	125	133	145	154	131	139	152	162	135	144	157	167		
MBh	32.0	32.7	35.0	37.4	31.3	32.0	34.1	36.5	30.5	31.2	33.3	35.6	29.8	30.4	32.5	34.8	28.3	28.9	30.9	33.0	26.2	26.8	28.6	30.6		
S/T	0.87	0.82	0.66	0.50	0.90	0.85	0.69	0.51	0.92	0.87	0.71	0.53	0.95	0.89	0.73	0.54	0.99	0.93	0.76	0.56	1.00	0.94	0.76	0.57		
ΔT	23	22	20	16	24	23	20	16	24	23	20	16	24	23	20	16	24	23	20	16	22	21	18	15		
kW	2.06	2.11	2.18	2.25	2.23	2.28	2.35	2.43	2.37	2.42	2.51	2.59	2.50	2.56	2.64	2.73	2.61	2.67	2.76	2.85	2.70	2.76	2.86	2.96		
Amps	7.6	7.8	8.1	8.4	8.3	8.5	8.7	9.1	9.0	9.2	9.5	9.9	9.6	9.9	10.2	10.6	10.3	10.5	10.9	11.3	10.9	11.2	11.5	12.0		
Hi PR	214	231	244	254	240	259	273	285	274	294	311	324	312	335	354	369	350	377	398	415	387	417	440	459		
Lo PR	105	111	122	130	111	118	129	137	115	122	134	142	121	129	140	149	127	135	147	157	131	139	152	162		

85	1406	MBh	36.4	37.1	38.8	41.4	35.5	36.2	37.9	40.4	34.7	35.3	37.0	39.5	33.8	34.5	36.1	38.5	32.1	32.7	34.3	36.6	29.8	30.3	31.8	33.9
		S/T	0.99	0.96	0.86	0.70	1.00	0.99	0.89	0.73	1.00	1.00	0.92	0.74	1.00	1.00	0.95	0.77	1.00	1.00	0.98	0.80	1.00	1.00	0.99	0.80
	ΔT	24	23	22	19	23	23	22	19	23	23	22	19	22	23	22	19	21	21	22	19	19	20	21	18	
	kW	2.15	2.20	2.27	2.35	2.32	2.37	2.45	2.54	2.47	2.53	2.62	2.71	2.61	2.67	2.76	2.86	2.72	2.79	2.88	2.98	2.82	2.89	2.99	3.09	
	Amps	8.0	8.2	8.5	8.8	8.7	8.9	9.2	9.5	9.4	9.7	10.0	10.4	10.1	10.3	10.7	11.1	10.8	11.0	11.4	11.9	11.4	11.7	12.1	12.6	
	Hi PR	225	243	256	267	253	272	287	300	288	310	327	341	328	353	372	388	369	397	419	437	407	438	463	483	
	Lo PR	110	117	128	136	116	124	135	144	121	129	141	150	127	135	148	157	133	142	155	165	138	147	160	170	
	MBh	35.3	36.0	37.7	40.2	34.5	35.1	36.8	39.3	33.7	34.3	35.9	38.3	32.8	33.5	35.1	37.4	31.2	31.8	33.3	35.5	28.9	29.5	30.8	32.9	
	S/T	0.95	0.91	0.82	0.67	0.98	0.95	0.85	0.69	1.00	0.97	0.88	0.71	1.00	1.00	0.90	0.73	1.00	1.00	0.94	0.76	1.00	1.00	0.95	0.77	
	ΔT	25	24	23	20	25	24	23	20	25	24	23	20	24	25	23	20	23	23	23	20	21	22	21	19	
kW	2.13	2.18	2.25	2.33	2.30	2.35	2.43	2.52	2.45	2.51	2.59	2.68	2.59	2.65	2.74	2.83	2.70	2.76	2.86	2.96	2.80	2.86	2.96	3.07		
Amps	7.9	8.1	8.4	8.7	8.6	8.8	9.1	9.4	9.3	9.6	9.9	10.3	10.0	10.2	10.6	11.0	10.7	10.9	11.3	11.7	11.3	11.6	12.0	12.5		
Hi PR	223	240	254	265	250	269	285	297	285	306	324	338	324	349	369	384	365	393	415	433	403	434	458	478		
Lo PR	109	116	127	135	115	123	134	143	120	127	139	148	126	134	146	156	132	140	153	163	136	145	158	169		
MBh	32.6	33.2	34.8	37.1	31.8	32.4	34.0	36.2	31.1	31.7	33.2	35.4	30.3	30.9	32.4	34.5	28.8	29.3	30.7	32.8	26.7	27.2	28.5	30.4		
S/T	0.91	0.88	0.79	0.64	0.94	0.91	0.82	0.67	0.97	0.93	0.84	0.68	1.00	0.97	0.87	0.71	1.00	1.00	0.90	0.73	1.00	1.00	0.91	0.74		
ΔT	25	25	23	20	25	25	23	20	25	25	24	20	25	25	24	21	24	25	23	20	22	23	22	19		
kW	2.08	2.12	2.19	2.27	2.24	2.29	2.37	2.45	2.39	2.45	2.53	2.61	2.52	2.58	2.67	2.76	2.63	2.69	2.78	2.88	2.73	2.79	2.88	2.98		
Amps	7.7	7.9	8.1	8.5	8.3	8.5	8.8	9.2	9.1	9.3	9.6	10.0	9.7	10.0	10.3	10.7	10.4	10.6	11.0	11.4	11.0	11.3	11.7	12.1		
Hi PR	216	233	246	257	243	261	276	288	276	297	314	327	315	339	358	373	354	381	402	420	391	421	444	464		
Lo PR	106	113	123	131	112	119	130	138	116	124	135	144	122	130	142	151	128	136	149	158	132	141	154	164		

kW = Total system power  
Amps = outdoor unit amps (compressor + fan)

Shaded area reflects AHRI (TVA) conditions

IDB: Entering Indoor Dry Bulb Temperature  
High and low pressures are measured at the liquid and suction service valves.

EXPANDED COOLING DATA — ASZC180481A\*/CA\*F3743\*6\*\*+TXV/MBVC2000\*\* — LOW STAGE

IDB	OUTDOOR AMBIENT TEMPERATURE												ENTERING INDOOR WET BULB TEMPERATURE											
	65°F				75°F				85°F				95°F				105°F				115°F			
	59	63	67	71	59	63	67	71	59	63	67	71	59	63	67	71	59	63	67	71	59	63	67	71
70	AIRFLOW																							
	MBh																							
	S/T																							
	ΔT																							
	1350																							
	kW																							
	Amps																							
	HiPR																							
	Lo PR																							
	1200																							
kW																								
Amps																								
HiPR																								
Lo PR																								
1050																								
MBh																								
S/T																								
ΔT																								
kW																								
Amps																								
HiPR																								
Lo PR																								

75	AIRFLOW																							
	MBh																							
	S/T																							
	ΔT																							
	1350																							
	kW																							
	Amps																							
	HiPR																							
	Lo PR																							
	1200																							
kW																								
Amps																								
HiPR																								
Lo PR																								
1050																								
MBh																								
S/T																								
ΔT																								
kW																								
Amps																								
HiPR																								
Lo PR																								

IDB: Entering Indoor Dry Bulb Temperature  
 High and low pressures are measured at the liquid and suction service valves.  
 Shaded area reflects ACCA (TVA) conditions  
 kW = Total system power  
 Amps = outdoor unit amps (compressor + fan)

EXPANDED COOLING DATA — ASZC180481A\*/CA\*F3743\*6\*\*\*+TXV/MBVC2000\*\* — LOW STAGE (CONT.)

IDB	OUTDOOR AMBIENT TEMPERATURE												ENTERING INDOOR WET BULB TEMPERATURE												
	65°F				75°F				85°F				95°F				105°F				115°F				
	59	63	67	71	59	63	67	71	59	63	67	71	59	63	67	71	59	63	67	71	59	63	67	71	
1350	MBh	36.3	37.1	39.6	42.3	35.4	36.2	38.7	41.3	34.6	35.3	37.7	40.3	33.7	34.5	36.8	39.4	32.0	32.7	35.0	37.4	29.7	30.3	32.4	34.6
	S/T	0.94	0.88	0.72	0.54	1.00	0.92	0.75	0.56	1.00	0.94	0.76	0.57	1.00	0.97	0.79	0.59	1.00	1.00	0.82	0.61	1.00	1.00	0.83	0.62
	ΔT	23	22	19	15	24	23	20	16	24	23	20	16	23	23	20	16	22	22	20	16	20	21	18	15
	kW	1.88	1.93	1.99	2.06	2.04	2.09	2.16	2.24	2.18	2.24	2.31	2.40	2.31	2.36	2.45	2.53	2.41	2.47	2.56	2.65	2.50	2.56	2.65	2.75
	Amps	0.1	0.1	0.1	0.1	0.1	0.1	0.1	0.1	0.1	0.1	0.1	0.1	0.1	0.1	0.1	0.1	0.1	0.1	0.1	0.1	0.1	0.1	0.1	0.1
	Hi PR	213	229	242	252	239	257	272	283	272	292	309	322	310	333	352	367	348	375	396	413	385	414	437	456
	Lo PR	112	119	130	139	118	126	138	147	123	131	143	152	129	138	150	160	136	144	157	168	140	149	163	173
	MBh	35.2	36.0	38.4	41.1	34.4	35.1	37.5	40.1	33.6	34.3	36.6	39.2	32.7	33.5	35.8	38.2	31.1	31.8	34.0	36.3	28.8	29.4	31.5	33.6
	S/T	0.90	0.84	0.69	0.51	0.93	0.87	0.71	0.53	0.96	0.90	0.73	0.54	0.99	0.92	0.75	0.56	1.00	0.96	0.78	0.58	1.00	0.97	0.79	0.59
	ΔT	24	23	20	16	25	24	20	16	25	24	20	16	25	24	21	16	24	23	20	16	22	22	19	15
1200	kW	1.87	1.91	1.98	2.05	2.03	2.07	2.15	2.22	2.16	2.22	2.29	2.38	2.29	2.34	2.42	2.51	2.39	2.45	2.54	2.63	2.48	2.54	2.63	2.73
	Amps	0.1	0.1	0.1	0.1	0.1	0.1	0.1	0.1	0.1	0.1	0.1	0.1	0.1	0.1	0.1	0.1	0.1	0.1	0.1	0.1	0.1	0.1	0.1	0.1
	Hi PR	211	227	240	250	237	255	269	280	269	290	306	319	307	330	348	363	345	371	392	409	381	410	433	452
	Lo PR	111	118	129	137	117	125	136	145	122	130	142	151	128	136	149	158	134	143	156	166	139	148	161	172
	MBh	32.5	33.2	35.5	37.9	31.7	32.4	34.6	37.0	31.0	31.7	33.8	36.2	30.2	30.9	33.0	35.3	28.7	29.3	31.3	33.5	26.6	27.2	29.0	31.0
	S/T	0.87	0.81	0.66	0.49	0.90	0.84	0.69	0.51	0.92	0.86	0.70	0.53	0.95	0.89	0.73	0.54	0.99	0.93	0.75	0.56	0.99	0.93	0.76	0.57
	ΔT	25	24	21	16	25	24	21	17	25	24	21	17	25	24	21	17	25	24	21	17	23	22	19	15
	kW	1.82	1.86	1.93	1.99	1.97	2.02	2.09	2.16	2.11	2.16	2.23	2.31	2.23	2.28	2.36	2.44	2.33	2.38	2.47	2.56	2.41	2.47	2.56	2.65
	Amps	0.1	0.1	0.1	0.1	0.1	0.1	0.1	0.1	0.1	0.1	0.1	0.1	0.1	0.1	0.1	0.1	0.1	0.1	0.1	0.1	0.1	0.1	0.1	0.1
	Hi PR	205	220	232	242	230	247	261	272	261	281	297	309	297	320	338	352	334	360	380	396	370	398	420	438
Lo PR	108	115	125	133	114	121	132	141	118	126	137	146	124	132	144	154	130	138	151	161	135	143	156	167	

1350	MBh	36.9	37.6	39.4	42.0	36.0	36.7	38.5	41.0	35.2	35.9	37.6	40.1	34.3	35.0	36.6	39.1	32.6	33.2	34.8	37.1	30.2	30.8	32.2	34.4
	S/T	0.99	0.95	0.86	0.70	1.00	0.99	0.89	0.72	1.00	1.00	0.91	0.74	1.00	1.00	0.94	0.77	1.00	1.00	0.98	0.79	1.00	1.00	0.99	0.80
	ΔT	25	24	23	20	25	25	23	20	24	24	23	20	23	24	24	20	22	23	23	20	21	21	22	19
	kW	1.90	1.94	2.01	2.08	2.06	2.11	2.18	2.26	2.20	2.26	2.33	2.42	2.33	2.38	2.47	2.56	2.43	2.49	2.58	2.67	2.53	2.59	2.68	2.78
	Amps	0.1	0.1	0.1	0.1	0.1	0.1	0.1	0.1	0.1	0.1	0.1	0.1	0.1	0.1	0.1	0.1	0.1	0.1	0.1	0.1	0.1	0.1	0.1	0.1
	Hi PR	215	231	244	255	241	260	274	286	275	295	312	325	313	336	355	371	352	379	400	417	389	418	442	461
	Lo PR	113	120	132	140	120	127	139	148	124	132	144	154	131	139	152	162	137	146	159	169	142	151	164	175
	MBh	35.8	36.5	38.2	40.8	35.0	35.7	37.4	39.8	34.2	34.8	36.5	38.9	33.3	34.0	35.6	38.0	31.7	32.3	33.8	36.1	29.3	29.9	31.3	33.4
	S/T	0.94	0.91	0.82	0.67	0.98	0.94	0.85	0.69	1.00	0.97	0.87	0.71	1.00	1.00	0.90	0.73	1.00	1.00	0.93	0.76	1.00	1.00	0.94	0.76
	ΔT	26	25	24	21	26	26	24	21	26	26	24	21	26	26	25	21	24	25	24	21	22	23	23	20
1200	kW	1.88	1.93	1.99	2.06	2.04	2.09	2.16	2.24	2.18	2.24	2.31	2.40	2.31	2.36	2.45	2.53	2.41	2.47	2.56	2.65	2.50	2.56	2.65	2.75
	Amps	0.1	0.1	0.1	0.1	0.1	0.1	0.1	0.1	0.1	0.1	0.1	0.1	0.1	0.1	0.1	0.1	0.1	0.1	0.1	0.1	0.1	0.1	0.1	0.1
	Hi PR	213	229	242	252	239	257	272	283	272	292	309	322	310	333	352	367	348	375	396	413	385	414	437	456
	Lo PR	112	119	130	139	118	126	138	147	123	131	143	152	129	138	150	160	136	144	157	168	140	149	163	173
	MBh	33.1	33.7	35.3	37.7	32.3	32.9	34.5	36.8	31.5	32.1	33.7	35.9	30.8	31.4	32.8	35.0	29.2	29.8	31.2	33.3	27.1	27.6	28.9	30.8
	S/T	0.91	0.88	0.79	0.64	0.94	0.91	0.82	0.67	0.97	0.93	0.84	0.68	1.00	0.96	0.87	0.70	1.00	1.00	0.90	0.73	1.00	1.00	0.91	0.74
	ΔT	26.3	26	24	21	27	26	25	21	27	26	25	21	27	26	25	22	26	26	25	21	24	24	23	20
	kW	1.84	1.88	1.94	2.01	1.99	2.04	2.11	2.18	2.13	2.18	2.25	2.33	2.25	2.30	2.38	2.47	2.35	2.40	2.49	2.58	2.44	2.49	2.58	2.68
	Amps	0.1	0.1	0.1	0.1	0.1	0.1	0.1	0.1	0.1	0.1	0.1	0.1	0.1	0.1	0.1	0.1	0.1	0.1	0.1	0.1	0.1	0.1	0.1	0.1
	Hi PR	207	222	235	245	232	249	263	275	264	284	300	312	300	323	341	356	338	364	384	400	373	402	424	442
Lo PR	109	116	126	135	115	122	133	142	119	127	139	148	125	133	146	155	131	140	153	163	136	145	158	168	

kW = Total system power  
Amps = outdoor unit amps (compressor + fan)

Shaded area reflects AHRI (TVA) conditions

IDB: Entering Indoor Dry Bulb Temperature  
High and low pressures are measured at the liquid and suction service valves.

EXPANDED COOLING DATA — ASZC180481A\*/CA\*F3743\*6\*\*+TXV/MBVC2000\*\* — HIGH STAGE

IDB	AIRFLOW	OUTDOOR AMBIENT TEMPERATURE												ENTERING INDOOR WET BULB TEMPERATURE													
		65°F				75°F				85°F				95°F				105°F				115°F					
		59	63	67	71	59	63	67	71	59	63	67	71	59	63	67	71	59	63	67	71	59	63	67	71		
70	1969	MBh	49.0	50.8	55.6	-	47.9	49.6	54.3	-	46.7	48.4	53.1	-	45.6	47.2	51.8	-	43.3	44.9	49.2	-	40.1	41.6	45.5	-	
		S/T	0.75	0.63	0.44	-	0.78	0.65	0.45	-	0.80	0.67	0.46	-	0.83	0.69	0.48	-	0.86	0.72	0.50	-	0.87	0.72	0.50	-	
	1750	ΔT	17	15	11	-	17	15	11	-	17	15	11	-	18	15	12	-	17	15	11	-	16	14	11	-	
		kW	2.88	2.94	3.04	-	3.10	3.17	3.28	-	3.31	3.38	3.49	-	3.48	3.56	3.68	-	3.63	3.72	3.84	-	3.76	3.85	3.98	-	
	1531	Amps	10.3	10.6	10.9	-	11.2	11.5	11.8	-	12.2	12.5	12.9	-	13.1	13.4	13.9	-	13.9	14.3	14.8	-	14.8	15.2	15.7	-	
		Hi PR	214	231	244	-	241	259	273	-	274	295	311	-	312	335	354	-	351	377	399	-	387	417	440	-	
	70	Lo PR	106	113	123	-	112	119	130	-	116	124	135	-	122	130	142	-	128	136	149	-	132	141	154	-	
			47.6	49.3	54.0	-	46.5	48.2	52.8	-	45.4	47.0	51.5	-	44.3	45.9	50.3	-	42.0	43.6	47.7	-	38.9	40.4	44.2	-	
	75	1969	MBh	49.8	51.3	55.5	59.6	48.7	50.1	54.2	58.2	47.5	48.9	52.9	56.8	46.4	47.7	51.7	55.4	44.0	45.3	49.1	52.7	40.8	42.0	45.5	48.8
			S/T	0.86	0.77	0.58	0.37	0.89	0.79	0.60	0.39	0.91	0.81	0.62	0.40	0.94	0.84	0.64	0.41	0.98	0.87	0.66	0.42	0.98	0.88	0.67	0.43
1750		ΔT	20	18	15	10	20	19	15	11	20	19	15	11	20	19	15	11	20	18	15	10	19	17	14	10	
		kW	2.90	2.96	3.06	3.16	3.13	3.20	3.31	3.42	3.33	3.41	3.52	3.64	3.51	3.59	3.71	3.84	3.67	3.75	3.88	4.01	3.80	3.88	4.02	4.16	
1531		Amps	10.4	10.7	11.0	11.4	11.3	11.6	12.0	12.4	12.3	12.6	13.0	13.6	13.2	13.5	14.0	14.5	14.1	14.4	14.9	15.5	14.9	15.3	15.9	16.5	
		Hi PR	217	233	246	257	243	262	276	288	277	298	314	328	315	339	358	373	354	381	403	420	391	421	445	464	
75		Lo PR	107	114	124	132	113	120	131	140	118	125	137	145	123	131	143	153	129	138	150	160	134	142	155	166	
			48.4	49.8	53.9	57.9	47.3	48.6	52.7	56.5	46.1	47.5	51.4	55.2	45.0	46.3	50.2	53.8	42.8	44.0	47.6	51.1	39.6	40.8	44.1	47.4	
75		1969	MBh	48.4	49.8	53.9	57.9	47.3	48.6	52.7	56.5	46.1	47.5	51.4	55.2	45.0	46.3	50.2	53.8	42.8	44.0	47.6	51.1	39.6	40.8	44.1	47.4
			S/T	0.82	0.73	0.55	0.36	0.85	0.76	0.57	0.37	0.87	0.78	0.59	0.38	0.90	0.80	0.61	0.39	0.93	0.83	0.63	0.41	0.94	0.84	0.64	0.41
	1750	ΔT	21	19	16	11	21	19	16	11	21	19	16	11	21	20	16	11	21	19	16	11	20	18	15	10	
		kW	2.88	2.94	3.04	3.14	3.11	3.17	3.28	3.39	3.31	3.38	3.49	3.61	3.48	3.56	3.68	3.81	3.63	3.72	3.84	3.98	3.76	3.85	3.98	4.12	
	1531	Amps	10.3	10.6	10.9	11.3	11.2	11.5	11.8	12.3	12.2	12.5	12.9	13.4	13.1	13.4	13.9	14.4	13.9	14.3	14.8	15.4	14.8	15.2	15.7	16.3	
		Hi PR	215	231	244	254	241	259	274	285	274	295	311	324	312	336	354	370	351	377	399	416	388	417	440	459	
	75	Lo PR	106	113	123	131	112	119	130	138	116	124	135	144	122	130	142	151	128	136	149	158	133	141	154	164	
			44.7	46.0	49.8	53.4	43.6	44.9	48.6	52.2	42.6	43.8	47.4	50.9	41.5	42.8	46.3	49.7	39.5	40.6	44.0	47.2	36.6	37.6	40.7	43.7	
	75	1969	MBh	49.8	51.3	55.5	59.6	48.7	50.1	54.2	58.2	47.5	48.9	52.9	56.8	46.4	47.7	51.7	55.4	44.0	45.3	49.1	52.7	40.8	42.0	45.5	48.8
			S/T	0.86	0.77	0.58	0.37	0.89	0.79	0.60	0.39	0.91	0.81	0.62	0.40	0.94	0.84	0.64	0.41	0.98	0.87	0.66	0.42	0.98	0.88	0.67	0.43
1750		ΔT	20	18	15	10	20	19	15	11	20	19	15	11	20	19	15	11	20	18	15	10	19	17	14	10	
		kW	2.90	2.96	3.06	3.16	3.13	3.20	3.31	3.42	3.33	3.41	3.52	3.64	3.51	3.59	3.71	3.84	3.67	3.75	3.88	4.01	3.80	3.88	4.02	4.16	
1531		Amps	10.4	10.7	11.0	11.4	11.3	11.6	12.0	12.4	12.3	12.6	13.0	13.6	13.2	13.5	14.0	14.5	14.1	14.4	14.9	15.5	14.9	15.3	15.9	16.5	
		Hi PR	217	233	246	257	243	262	276	288	277	298	314	328	315	339	358	373	354	381	403	420	391	421	445	464	
75		Lo PR	107	114	124	132	113	120	131	140	118	125	137	145	123	131	143	153	129	138	150	160	134	142	155	166	
			48.4	49.8	53.9	57.9	47.3	48.6	52.7	56.5	46.1	47.5	51.4	55.2	45.0	46.3	50.2	53.8	42.8	44.0	47.6	51.1	39.6	40.8	44.1	47.4	
75		1969	MBh	49.8	51.3	55.5	59.6	48.7	50.1	54.2	58.2	47.5	48.9	52.9	56.8	46.4	47.7	51.7	55.4	44.0	45.3	49.1	52.7	40.8	42.0	45.5	48.8
			S/T	0.86	0.77	0.58	0.37	0.89	0.79	0.60	0.39	0.91	0.81	0.62	0.40	0.94	0.84	0.64	0.41	0.98	0.87	0.66	0.42	0.98	0.88	0.67	0.43
	1750	ΔT	20	18	15	10	20	19	15	11	20	19	15	11	20	19	15	11	20	18	15	10	19	17	14	10	
		kW	2.90	2.96	3.06	3.16	3.13	3.20	3.31	3.42	3.33	3.41	3.52	3.64	3.51	3.59	3.71	3.84	3.67	3.75	3.88	4.01	3.80	3.88	4.02	4.16	
	1531	Amps	10.4	10.7	11.0	11.4	11.3	11.6	12.0	12.4	12.3	12.6	13.0	13.6	13.2	13.5	14.0	14.5	14.1	14.4	14.9	15.5	14.9	15.3	15.9	16.5	
		Hi PR	217	233	246	257	243	262	276	288	277	298	314	328	315	339	358	373	354	381	403	420	391	421	445	464	
	75	Lo PR	107	114	124	132	113	120	131	140	118	125	137	145	123	131	143	153	129	138	150	160	134	142	155	166	
			48.4	49.8	53.9	57.9	47.3	48.6	52.7	56.5	46.1	47.5	51.4	55.2	45.0	46.3	50.2	53.8	42.8	44.0	47.6	51.1	39.6	40.8	44.1	47.4	
	75	1969	MBh	49.8	51.3	55.5	59.6	48.7	50.1	54.2	58.2	47.5	48.9	52.9	56.8	46.4	47.7	51.7	55.4	44.0	45.3	49.1	52.7	40.8	42.0	45.5	48.8
			S/T	0.86	0.77	0.58	0.37	0.89	0.79	0.60	0.39	0.91	0.81	0.62	0.40	0.94	0.84	0.64	0.41	0.98	0.87	0.66	0.42	0.98	0.88	0.67	0.43
1750		ΔT	20	18	15	10	20	19	15	11	20	19	15	11	20	19	15	11	20	18	15	10	19	17	14	10	
		kW	2.90	2.96	3.06	3.16	3.13	3.20	3.31	3.42	3.33	3.41	3.52	3.64	3.51	3.59	3.71	3.84	3.67	3.75	3.88	4.01	3.80	3.88	4.02	4.16	
1531		Amps	10.4	10.7	11.0	11.4	11.3	11.6	12.0	12.4	12.3	12.6	13.0	13.6	13.2	13.5	14.0	14.5	14.1	14.4	14.9	15.5	14.9	15.3	15.9	16.5	
		Hi PR	217	233	246	257	243	262	276	288	277	298	314	328	315	339	358	373	354	381	403	420	391	421	445	464	
75		Lo PR	107	114	124	132	113	120	131	140	118	125	137	145	123	131	143	153	129	138	150	160	134	142	155	166	
			48.4	49.8	53.9	57.9	47.3	48.6	52.7	56.5	46.1	47.5	51.4	55.2	45.0	46.3	50.2	53.8	42.8	44.0	47.6	51.1	39.6	40.8	44.1	47.4	
75		1969	MBh	49.8	51.3	55.5	59.6	48.7	50.1	54.2	58.2	47.5	48.9	52.9	56.8	46.4	47.7	51.7	55.4	44.0	45.3	49.1	52.7	40.8	42.0	45.5	48.8
			S/T	0.86	0.77	0.58	0.37	0.89	0.79	0.60	0.39	0.91	0.81	0.62	0.40	0.94	0.84	0.64	0.41	0.98	0.87	0.66	0.42	0.98	0.88	0.67	0.43
	1750	ΔT	20	18	15	10	20	19	15	11	20	19	15	11	20	19	15	11	20	18	15	10	19	17	14	10	
		kW	2.90	2.96	3.06	3.16	3.13	3.20	3.31	3.42	3.33	3.41	3.52	3.64	3.51	3.59	3.71	3.84	3.67	3.75	3.88	4.01	3.80	3.88	4.02	4.16	

EXPANDED COOLING DATA — ASZC180481A\*/CA\*F3743\*6\*\*\*+TXV/MBVC2000\*\* — HIGH STAGE (CONT.)

IDB	AIRFLOW	OUTDOOR AMBIENT TEMPERATURE												ENTERING INDOOR WET BULB TEMPERATURE													
		65°F				75°F				85°F				95°F				105°F				115°F					
		59	63	67	71	59	63	67	71	59	63	67	71	59	63	67	71	59	63	67	71	59	63	67	71		
80	1969	MBh	50.7	51.8	55.4	59.2	49.5	50.6	54.1	57.8	48.4	49.4	52.8	56.4	47.2	48.2	51.5	55.1	44.8	45.8	48.9	52.3	41.5	42.4	45.3	48.4	
		S/T	0.94	0.88	0.72	0.54	1.00	0.91	0.74	0.56	1.00	0.94	0.76	0.57	1.00	0.97	0.79	0.59	1.00	1.00	0.82	0.61	1.00	1.00	0.82	0.62	
	ΔT	22	21	19	15	23	22	19	15	22	22	19	15	22	22	19	15	21	21	19	15	19	20	17	14		
	1750	kW	2.93	2.99	3.09	3.19	3.16	3.23	3.33	3.45	3.36	3.44	3.55	3.67	3.54	3.62	3.75	3.87	3.70	3.78	3.91	4.05	3.83	3.92	4.05	4.19	
		Amps	10.5	10.8	11.1	11.6	11.4	11.7	12.1	12.5	12.4	12.7	13.2	13.7	13.3	13.6	14.1	14.7	14.2	14.6	15.1	15.7	15.1	15.5	16.0	16.6	
	1531	HiPR	219	236	249	259	246	264	279	291	279	301	317	331	318	342	361	377	358	385	407	424	395	426	449	469	
		Lo PR	108	115	126	134	114	122	133	141	119	126	138	147	125	133	145	154	131	139	152	162	135	144	157	167	
	80	1750	MBh	49.2	50.3	53.8	57.5	48.1	49.1	52.5	56.1	46.9	48.0	51.3	54.8	45.8	46.8	50.0	53.5	43.5	44.5	47.5	50.8	40.3	41.2	44.0	47.0
			S/T	0.90	0.84	0.68	0.51	0.93	0.87	0.71	0.53	0.95	0.89	0.73	0.54	0.98	0.92	0.75	0.56	1.00	0.96	0.78	0.58	1.00	0.97	0.79	0.59
		ΔT	23	22	19	15	23	22	19	15	23	23	20	16	24	23	20	16	24	23	22	19	16	21	18	15	
1531		kW	2.90	2.96	3.06	3.16	3.13	3.20	3.31	3.42	3.33	3.41	3.52	3.64	3.51	3.59	3.71	3.84	3.67	3.75	3.88	4.01	3.80	3.88	4.02	4.16	
		Amps	10.4	10.7	11.0	11.5	11.3	11.6	12.0	12.4	12.3	12.6	13.0	13.6	13.2	13.5	14.0	14.5	14.1	14.4	14.9	15.5	14.9	15.3	15.9	16.5	
1531		HiPR	217	233	246	257	243	262	276	288	277	298	314	328	315	339	358	373	354	381	403	420	391	421	445	464	
		Lo PR	107	114	124	132	113	120	131	140	118	125	137	145	123	131	143	153	129	138	150	160	134	142	155	166	
80		1531	MBh	45.4	46.4	49.6	53.0	44.4	45.4	48.5	51.8	43.3	44.3	47.3	50.6	42.3	43.2	46.2	49.3	40.2	41.0	43.8	46.9	37.2	38.0	40.6	43.4
			S/T	0.86	0.81	0.66	0.49	0.90	0.84	0.68	0.51	0.92	0.86	0.70	0.52	0.95	0.89	0.72	0.54	0.98	0.92	0.75	0.56	0.99	0.93	0.76	0.57
		ΔT	24	23	20	16	24	23	20	16	24	23	20	16	24	23	20	16	24	23	22	19	16	21	18	15	
	1531	kW	2.83	2.89	2.98	3.08	3.05	3.12	3.22	3.33	3.25	3.32	3.43	3.55	3.42	3.50	3.62	3.74	3.57	3.65	3.78	3.91	3.70	3.78	3.91	4.05	
		Amps	10.1	10.4	10.7	11.1	11.0	11.2	11.6	12.1	11.9	12.3	12.7	13.2	12.8	13.1	13.6	14.1	13.7	14.0	14.5	15.1	14.5	14.9	15.4	16.0	
	1531	HiPR	210	226	239	249	236	254	268	280	268	289	305	318	306	329	347	362	344	370	391	407	380	409	432	450	
		Lo PR	104	110	121	128	110	117	127	136	114	121	132	141	120	127	139	148	126	134	146	155	130	138	151	161	

85	1969	MBh	51.6	52.6	55.1	58.8	50.4	51.4	53.8	57.4	49.2	50.2	52.5	56.0	48.0	48.9	51.2	54.7	45.6	46.5	48.7	51.9	42.2	43.1	45.1	48.1	
		S/T	0.99	0.95	0.86	0.70	1.00	0.99	0.89	0.72	1.00	1.00	0.91	0.74	1.00	1.00	0.94	0.76	1.00	1.00	0.98	0.79	1.00	1.00	0.99	0.80	
	ΔT	24	23	22	19	24	24	22	19	23	23	22	19	22	23	23	19	21	22	22	19	20	20	21	18		
	1969	kW	2.95	3.01	3.11	3.22	3.18	3.25	3.36	3.48	3.39	3.47	3.58	3.71	3.57	3.65	3.78	3.91	3.73	3.81	3.94	4.08	3.86	3.95	4.09	4.23	
		Amps	10.6	10.9	11.2	11.7	11.5	11.8	12.2	12.7	12.5	12.9	13.3	13.8	13.4	13.8	14.3	14.8	14.3	14.7	15.2	15.8	15.2	15.6	16.2	16.8	
	1969	HiPR	221	238	251	262	248	267	282	294	282	304	321	334	321	346	365	381	361	389	411	428	399	430	454	473	
		Lo PR	109	116	127	135	115	123	134	143	120	128	139	148	126	134	146	156	132	140	153	163	137	145	159	169	
	85	1750	MBh	50.1	51.1	53.5	57.1	48.9	49.9	52.2	55.7	47.8	48.7	51.0	54.4	46.6	47.5	49.8	53.1	44.3	45.1	47.3	50.4	41.0	41.8	43.8	46.7
			S/T	0.94	0.91	0.82	0.66	0.97	0.94	0.85	0.69	1.00	0.96	0.87	0.71	1.00	0.99	0.90	0.73	1.00	1.00	0.93	0.76	1.00	1.00	0.94	0.76
		ΔT	25	24	23	20	25	25	23	20	25	25	23	20	24	25	23	20	24	25	24	23	20	22	22	19	
1750		kW	2.93	2.99	3.09	3.19	3.16	3.23	3.33	3.45	3.36	3.44	3.55	3.67	3.54	3.62	3.75	3.87	3.70	3.78	3.91	4.05	3.83	3.92	4.05	4.19	
		Amps	10.5	10.8	11.1	11.6	11.4	11.7	12.1	12.5	12.4	12.7	13.2	13.7	13.3	13.6	14.1	14.7	14.2	14.6	15.1	15.7	15.1	15.5	16.0	16.6	
1750		HiPR	219	236	249	259	246	264	279	291	279	301	317	331	318	342	361	377	358	385	407	424	395	426	449	469	
		Lo PR	108	115	126	134	114	122	133	141	119	126	138	147	125	133	145	154	131	139	152	162	135	144	157	167	
85		1531	MBh	46.2	47.1	49.4	52.7	45.2	46.0	48.2	51.4	44.1	44.9	47.1	50.2	43.0	43.8	45.9	49.0	40.9	41.7	43.6	46.5	37.9	38.6	40.4	43.1
			S/T	0.91	0.87	0.79	0.64	0.94	0.91	0.82	0.66	0.96	0.93	0.84	0.68	0.99	0.96	0.87	0.70	1.00	1.00	0.90	0.73	1.00	1.00	0.91	0.74
		ΔT	25	25	23	20	25	25	24	20	25	25	24	21	26	25	24	21	26	25	24	21	25	25	24	22	19
	1531	kW	2.85	2.92	3.01	3.11	3.08	3.15	3.25	3.36	3.28	3.35	3.46	3.58	3.45	3.53	3.65	3.77	3.60	3.68	3.81	3.94	3.73	3.82	3.95	4.08	
		Amps	10.2	10.5	10.8	11.2	11.1	11.3	11.7	12.2	12.1	12.4	12.8	13.3	12.9	13.3	13.7	14.3	13.8	14.1	14.6	15.2	14.6	15.0	15.5	16.2	
	1531	HiPR	212	228	241	252	238	256	271	282	271	292	308	321	309	332	351	366	347	374	394	411	384	413	436	455	
		Lo PR	105	112	122	130	111	118	129	137	115	123	134	142	121	129	140	150	127	135	147	157	131	139	152	162	

kW = Total system power  
Amps = outdoor unit amps (compressor + fan)

Shaded area reflects AHRI (TVA) conditions

IDB: Entering Indoor Dry Bulb Temperature  
High and low pressures are measured at the liquid and suction service valves.

EXPANDED COOLING DATA — ASZC180601B / CAPF4961D6\* +TXV / MBVC2000A — Low Stage

IDB	AIRFLOW	OUTDOOR AMBIENT TEMPERATURE																									
		65°F				75°F				85°F				95°F				105°F				115°F					
		59	63	67	71	59	63	67	71	59	63	67	71	59	63	67	71	59	63	67	71	59	63	67	71		
70	1350	MBh	40.0	41.5	45.5	-	39.1	40.5	44.4	-	38.2	39.6	43.3	-	37.2	38.6	42.3	-	35.4	36.7	40.2	-	32.8	34.0	37.2	-	
		S/T	0.73	0.61	0.42	-	0.76	0.63	0.44	-	0.78	0.65	0.45	-	0.80	0.67	0.47	-	0.83	0.70	0.48	-	0.84	0.70	0.49	-	
	1200	DT	20	17	13	-	20	18	13	-	20	18	13	-	20	18	13	-	20	17	13	-	19	16	12	-	
		kW	2.22	2.27	2.35	-	2.41	2.46	2.55	-	2.57	2.63	2.72	-	2.71	2.77	2.87	-	2.83	2.90	3.00	-	2.93	3.00	3.11	-	
	1050	Amps	7.9	8.1	8.3	-	8.5	8.7	9.0	-	9.2	9.4	9.7	-	9.8	10.1	10.4	-	10.5	10.7	11.1	-	11.1	11.3	11.7	-	
		Hi PR	206	222	234	-	231	249	263	-	263	283	299	-	300	322	340	-	337	363	383	-	372	401	423	-	
	75	1350	Lo PR	107	114	125	-	114	121	132	-	118	126	137	-	124	132	144	-	130	138	151	-	134	143	156	-
			MBh	38.9	40.3	44.1	-	38.0	39.3	43.1	-	37.1	38.4	42.1	-	36.2	37.5	41.1	-	34.3	35.6	39.0	-	31.8	33.0	36.1	-
		1200	S/T	0.70	0.58	0.40	-	0.72	0.61	0.42	-	0.74	0.62	0.43	-	0.77	0.64	0.44	-	0.80	0.66	0.46	-	0.80	0.67	0.46	-
			DT	21	18	14	-	21	18	14	-	21	18	14	-	21	18	14	-	21	18	14	-	20	17	13	-
1050		kW	2.21	2.26	2.33	-	2.39	2.44	2.52	-	2.55	2.60	2.69	-	2.69	2.75	2.84	-	2.81	2.87	2.97	-	2.91	2.98	3.08	-	
		Amps	7.8	8.0	8.3	-	8.4	8.6	8.9	-	9.1	9.4	9.7	-	9.8	10.0	10.3	-	10.4	10.6	11.0	-	11.0	11.2	11.6	-	
1050		Hi PR	204	220	232	-	229	246	260	-	260	280	296	-	297	319	337	-	334	359	379	-	369	397	419	-	
		Lo PR	106	113	124	-	112	120	131	-	117	124	136	-	123	131	143	-	129	137	149	-	133	142	155	-	
75		1350	MBh	35.9	37.2	40.7	-	35.0	36.3	39.8	-	34.2	35.5	38.8	-	33.4	34.6	37.9	-	31.7	32.9	36.0	-	29.4	30.4	33.3	-
			S/T	0.67	0.56	0.39	-	0.70	0.58	0.40	-	0.72	0.60	0.41	-	0.74	0.62	0.43	-	0.77	0.64	0.44	-	0.77	0.65	0.45	-
	1200	DT	21	18	14	-	21	19	14	-	21	19	14	-	22	19	14	-	22	19	14	-	20	17	13	-	
		kW	2.15	2.20	2.27	-	2.33	2.38	2.46	-	2.48	2.54	2.62	-	2.62	2.68	2.77	-	2.73	2.79	2.89	-	2.83	2.90	3.00	-	
	1050	Amps	7.6	7.8	8.0	-	8.2	8.4	8.7	-	8.9	9.1	9.4	-	9.5	9.7	10.0	-	10.1	10.3	10.7	-	10.7	10.9	11.3	-	
		Hi PR	198	213	225	-	222	239	252	-	253	272	287	-	288	310	327	-	324	348	368	-	358	385	406	-	
	75	1350	Lo PR	103	110	120	-	109	116	127	-	113	121	132	-	119	127	138	-	125	133	145	-	129	137	150	-
			MBh	40.7	41.9	45.4	48.7	39.8	40.9	44.3	47.6	38.8	40.0	43.3	46.4	37.9	39.0	42.2	45.3	36.0	37.0	40.1	43.0	33.3	34.3	37.1	39.9
		1200	S/T	0.83	0.75	0.56	0.36	0.86	0.77	0.58	0.38	0.89	0.79	0.60	0.39	0.91	0.82	0.62	0.40	0.95	0.85	0.64	0.41	0.96	0.86	0.65	0.42
			DT	23	21	17	12	23	22	18	12	23	22	18	12	24	22	18	12	23	21	18	12	22	20	16	11
1050		kW	2.24	2.29	2.37	2.45	2.43	2.48	2.57	2.66	2.59	2.65	2.74	2.84	2.73	2.80	2.89	3.00	2.85	2.92	3.02	3.13	2.96	3.03	3.14	3.25	
		Amps	8.0	8.1	8.4	8.7	8.6	8.8	9.1	9.4	9.3	9.5	9.8	10.2	9.9	10.2	10.5	10.9	10.6	10.8	11.2	11.6	11.2	11.4	11.8	12.3	
1050		Hi PR	208	224	237	247	234	251	266	277	266	286	302	315	303	326	344	359	340	366	387	404	376	405	427	446	
		Lo PR	109	115	126	134	115	122	133	142	119	127	138	147	125	133	145	155	131	140	152	162	136	144	158	168	
75		1350	MBh	39.5	40.7	44.0	47.3	38.6	39.7	43.0	46.2	37.7	38.8	42.0	45.1	36.8	37.9	41.0	44.0	34.9	36.0	38.9	41.8	32.4	33.3	36.1	38.7
			S/T	0.79	0.71	0.54	0.35	0.82	0.74	0.56	0.36	0.84	0.76	0.57	0.37	0.87	0.78	0.59	0.38	0.90	0.81	0.61	0.39	0.91	0.82	0.62	0.40
	1200	DT	24	22	18	13	24	22	18	13	24	22	18	13	25	23	19	13	24	22	18	13	23	21	17	12	
		kW	2.23	2.28	2.35	2.43	2.41	2.46	2.55	2.63	2.57	2.63	2.72	2.81	2.71	2.77	2.87	2.97	2.83	2.90	3.00	3.10	2.93	3.00	3.11	3.22	
	1050	Amps	7.9	8.1	8.3	8.6	8.5	8.7	9.0	9.3	9.2	9.4	9.7	10.1	9.8	10.1	10.4	10.8	10.5	10.7	11.1	11.5	11.1	11.3	11.7	12.2	
		Hi PR	206	222	234	244	231	249	263	274	263	283	299	312	300	322	341	355	337	363	383	400	372	401	423	441	
	1050	Lo PR	107	114	125	133	114	121	132	140	118	126	137	146	124	132	144	153	130	138	151	161	134	143	156	166	
		MBh	36.5	37.6	40.7	43.6	35.6	36.7	39.7	42.6	34.8	35.8	38.8	41.6	33.9	34.9	37.8	40.6	32.2	33.2	35.9	38.6	29.9	30.7	33.3	35.7	
	1050	S/T	0.77	0.69	0.52	0.33	0.79	0.71	0.54	0.35	0.81	0.73	0.55	0.35	0.84	0.75	0.57	0.37	0.87	0.78	0.59	0.38	0.88	0.79	0.60	0.38	
		DT	24	23	18	13	25	23	19	13	25	23	19	13	25	23	19	13	25	23	19	13	23	21	17	12	
1050	kW	2.17	2.22	2.29	2.37	2.35	2.40	2.48	2.56	2.50	2.56	2.65	2.74	2.64	2.70	2.79	2.89	2.76	2.82	2.92	3.02	2.86	2.92	3.03	3.13		
	Amps	7.7	7.9	8.1	8.4	8.3	8.5	8.7	9.1	9.0	9.2	9.5	9.8	9.6	9.8	10.1	10.5	10.2	10.4	10.8	11.2	10.8	11.0	11.4	11.8		
1050	Hi PR	200	215	227	237	224	241	255	266	255	275	290	302	291	313	330	344	327	352	372	388	361	389	411	428		
	Lo PR	104	111	121	129	110	117	128	136	114	122	133	142	120	128	140	149	126	134	146	156	130	139	151	161		

IDB: Entering Indoor Dry Bulb Temperature  
 High and low pressures are measured at the liquid and suction service valves.  
 Shaded area reflects ACCA (TVAV) conditions  
 kW = Total system power  
 Amps = outdoor unit amps (compressor + fan)

EXPANDED COOLING DATA — ASZC180601B / CAPF4961D6\* + TXV / MBVC2000A — LOW STAGE (CONT.)

IDB	AIRFLOW	OUTDOOR AMBIENT TEMPERATURE												ENTERING INDOOR WET BULB TEMPERATURE													
		65°F				75°F				85°F				95°F				105°F				115°F					
		59	63	67	71	59	63	67	71	59	63	67	71	59	63	67	71	59	63	67	71	59	63	67	71		
80	1350	MBh	41.4	42.3	45.2	48.4	40.5	41.4	44.2	47.2	39.5	40.4	43.1	46.1	38.5	39.4	42.1	45.0	36.6	37.4	40.0	42.7	33.9	34.7	37.0	39.6	
		S/T	0.91	0.86	0.70	0.52	0.95	0.89	0.72	0.54	1.00	0.91	0.74	0.55	1.00	0.94	0.77	0.57	1.00	1.00	0.79	0.59	1.00	1.00	0.80	0.60	
	1200	DT	26	25	21	17	26	25	22	17	27	25	22	17	26	25	22	18	25	25	22	17	23	24	20	16	
		kW	2.26	2.31	2.39	2.47	2.45	2.50	2.59	2.68	2.61	2.67	2.77	2.86	2.76	2.82	2.92	3.02	2.88	2.95	3.05	3.16	2.99	3.06	3.16	3.28	
	1050	Amps	8.0	8.2	8.5	8.8	8.7	8.9	9.1	9.5	9.4	9.6	9.9	10.3	10.0	10.3	10.6	11.0	10.7	10.9	11.3	11.7	11.3	11.5	11.9	12.4	
		Hi PR	210	226	239	249	236	254	268	280	268	289	305	318	306	329	347	362	344	370	391	408	380	409	432	450	
	85	1350	Lo PR	110	117	127	136	116	123	135	143	120	128	140	149	126	135	147	156	133	141	154	164	137	146	159	170
			MBh	40.2	41.1	43.9	46.9	39.3	40.1	42.9	45.9	38.4	39.2	41.9	44.8	37.4	38.2	40.9	43.7	35.5	36.3	38.8	41.5	32.9	33.6	35.9	38.4
		1200	S/T	0.87	0.82	0.67	0.50	0.90	0.85	0.69	0.52	0.93	0.87	0.71	0.53	0.96	0.90	0.73	0.55	0.99	0.93	0.76	0.57	1.00	0.94	0.76	0.57
			DT	27	26	22	18	27	26	23	18	27	26	23	18	27	26	23	18	27	26	23	18	25	24	21	17
1050		kW	2.24	2.29	2.37	2.45	2.43	2.48	2.57	2.66	2.59	2.65	2.74	2.84	2.73	2.80	2.89	3.00	2.86	2.92	3.02	3.13	2.96	3.03	3.14	3.25	
		Amps	8.0	8.1	8.4	8.7	8.6	8.8	9.1	9.4	9.3	9.5	9.8	10.2	9.9	10.2	10.5	10.9	10.6	10.8	11.2	11.6	11.2	11.4	11.8	12.3	
80		1350	Hi PR	208	224	237	247	234	251	266	277	266	286	302	315	303	326	344	359	341	366	387	404	376	405	428	446
			Lo PR	109	116	126	134	115	122	133	142	119	127	138	147	125	133	145	155	131	140	152	162	136	144	158	168
		1200	MBh	37.1	37.9	40.5	43.3	36.3	37.1	39.6	42.3	35.4	36.2	38.6	41.3	34.5	35.3	37.7	40.3	32.8	33.5	35.8	38.3	30.4	31.1	33.2	35.5
			S/T	0.84	0.79	0.64	0.48	0.87	0.82	0.67	0.50	0.89	0.84	0.68	0.51	0.92	0.86	0.70	0.53	0.96	0.90	0.73	0.55	0.97	0.91	0.74	0.55
	1050	DT	27	26	23	18	28	27	23	18	28	27	23	18	28	27	23	19	27	26	23	18	26	25	21	17	
		kW	2.19	2.24	2.31	2.39	2.37	2.42	2.50	2.59	2.52	2.58	2.67	2.76	2.66	2.72	2.82	2.92	2.78	2.84	2.94	3.05	2.88	2.95	3.05	3.16	
	85	1350	Amps	7.7	7.9	8.2	8.5	8.4	8.5	8.8	9.1	9.1	9.3	9.6	9.9	9.7	9.9	10.2	10.6	10.3	10.5	10.9	11.3	10.9	11.1	11.5	11.9
			Hi PR	202	217	230	239	227	244	258	269	258	277	293	306	294	316	334	348	330	355	375	391	365	393	415	433
		1200	Lo PR	105	112	122	130	111	118	129	138	116	123	134	143	121	129	141	150	127	135	148	157	132	140	153	163
			MBh	42.2	43.0	45.0	48.0	41.2	42.0	44.0	46.9	40.2	41.0	42.9	45.8	39.2	40.0	41.9	44.7	37.3	38.0	39.8	42.4	34.5	35.2	36.8	39.3
1050		S/T	0.96	0.92	0.83	0.68	0.99	0.96	0.86	0.70	1.00	0.98	0.89	0.72	1.00	1.00	0.92	0.74	1.00	1.00	0.95	0.77	1.00	1.00	0.96	0.78	
		DT	28	27	26	22	28	27	26	22	27	27	26	22	27	27	26	23	25	26	26	22	24	24	24	21	
80		1350	kW	2.28	2.33	2.41	2.50	2.47	2.53	2.61	2.70	2.64	2.70	2.79	2.89	2.78	2.85	2.95	3.05	2.91	2.97	3.08	3.19	3.01	3.08	3.19	3.31
			Amps	8.1	8.3	8.5	8.9	8.7	8.9	9.2	9.6	9.5	9.7	10.0	10.4	10.1	10.4	10.7	11.1	10.7	11.0	11.4	11.8	11.4	11.7	12.0	12.5
		1200	Hi PR	212	229	241	252	238	257	271	283	271	292	308	321	309	332	351	366	347	374	395	412	384	413	436	455
			Lo PR	111	118	129	137	117	124	136	145	122	129	141	150	128	136	148	158	134	142	155	166	138	147	161	171
	1050	MBh	40.9	41.7	43.7	46.6	40.0	40.7	42.7	45.5	39.0	39.8	41.7	44.4	38.1	38.8	40.6	43.4	36.2	36.9	38.6	41.2	33.5	34.2	35.8	38.2	
		S/T	0.91	0.88	0.80	0.65	0.95	0.91	0.82	0.67	0.97	0.94	0.85	0.69	1.00	0.97	0.87	0.71	1.00	1.00	0.91	0.74	1.00	1.00	0.91	0.74	
	85	1350	DT	29	28	27	23	29	29	27	23	29	29	27	23	29	29	27	24	28	28	27	23	26	26	25	22
			kW	2.26	2.31	2.39	2.47	2.45	2.50	2.59	2.68	2.61	2.67	2.77	2.86	2.76	2.82	2.92	3.02	2.88	2.95	3.05	3.16	2.99	3.06	3.16	3.28
		1200	Amps	8.0	8.2	8.5	8.8	8.7	8.9	9.1	9.5	9.4	9.6	9.9	10.3	10.0	10.3	10.6	11.0	10.7	10.9	11.3	11.7	11.3	11.5	11.9	12.4
			Hi PR	210	226	239	249	236	254	268	280	268	289	305	318	306	329	347	362	344	370	391	408	380	409	432	450
1050		Lo PR	110	117	127	136	116	123	135	143	120	128	140	149	126	135	147	156	133	141	154	164	137	146	159	170	
		MBh	37.8	38.5	40.3	43.0	36.9	37.6	39.4	42.0	36.0	36.7	38.5	41.0	35.1	35.8	37.5	40.0	33.4	34.0	35.6	38.0	30.9	31.5	33.0	35.2	
80		S/T	0.88	0.85	0.77	0.62	0.91	0.88	0.80	0.65	0.94	0.90	0.82	0.66	0.97	0.93	0.84	0.68	1.00	0.97	0.87	0.71	1.00	0.98	0.88	0.71	
		DT	29	29	27	23	30	29	27	24	30	29	27	24	30	29	28	24	29	29	27	24	27	27	25	22	
85		kW	2.21	2.26	2.33	2.41	2.39	2.44	2.52	2.61	2.54	2.60	2.69	2.79	2.69	2.75	2.84	2.94	2.80	2.87	2.97	3.07	2.91	2.98	3.08	3.19	
		Amps	7.8	8.0	8.3	8.5	8.4	8.6	8.9	9.2	9.1	9.4	9.7	10.0	9.7	10.0	10.3	10.7	10.4	10.6	11.0	11.4	11.0	11.2	11.6	12.0	
80	Hi PR	204	220	232	242	229	246	260	271	260	280	296	309	297	319	337	351	334	359	379	395	369	397	419	437		
	Lo PR	106	113	124	132	112	120	131	139	117	124	136	144	123	131	142	152	129	137	149	159	133	141	154	165		

IDB: Entering Indoor Dry Bulb Temperature  
 High and low pressures are measured at the liquid and suction service valves.  
 Shaded area reflects AHRI (TVA) conditions  
 Amps = outdoor unit amps (compressor + fan)  
 kW = Total system power

EXPANDED COOLING DATA — ASZC180601B / CAPF4961D6\* +TXV / MBVC2000A — HIGH STAGE

IDB	AIRFLOW	OUTDOOR AMBIENT TEMPERATURE																									
		65°F				75°F				85°F				95°F				105°F				115°F					
		59	63	67	71	59	63	67	71	59	63	67	71	59	63	67	71	59	63	67	71	59	63	67	71		
70	2000	MBh	54.6	56.5	62.0	-	53.3	55.2	60.5	-	52.0	53.9	59.1	-	50.8	52.6	57.6	-	48.2	50.0	54.8	-	44.7	46.3	50.7	-	
		S/T	0.73	0.61	0.42	-	0.76	0.63	0.44	-	0.78	0.65	0.45	-	0.80	0.67	0.47	-	0.83	0.70	0.48	-	0.84	0.70	0.49	-	
	1800	DT	18	16	12	-	19	16	12	-	19	16	12	-	19	16	12	-	19	16	12	-	17	15	11	-	
		kW	3.48	3.55	3.67	-	3.75	3.83	3.95	-	3.98	4.07	4.20	-	4.19	4.28	4.42	-	4.37	4.46	4.61	-	4.52	4.62	4.77	-	
	1600	Amps	13.0	13.3	13.8	-	14.1	14.4	14.9	-	15.3	15.7	16.2	-	16.4	16.8	17.4	-	17.5	17.9	18.5	-	18.5	19.0	19.7	-	
		Hi PR	206	222	235	-	232	249	263	-	263	283	299	-	300	323	341	-	338	363	384	-	373	401	424	-	
	75	2000	Lo PR	106	113	124	-	112	120	131	-	117	124	136	-	123	131	143	-	129	137	149	-	133	142	155	-
			MBh	53.8	55.7	61.0	-	52.5	54.4	59.6	-	51.3	53.1	58.2	-	50.0	51.8	56.8	-	47.5	49.2	53.9	-	44.0	45.6	50.0	-
		1800	S/T	0.70	0.59	0.41	-	0.73	0.61	0.42	-	0.75	0.62	0.43	-	0.77	0.64	0.45	-	0.80	0.67	0.46	-	0.81	0.67	0.47	-
			DT	19	17	13	-	20	17	13	-	20	17	13	-	20	17	13	-	19	17	13	-	18	16	12	-
		1600	kW	3.46	3.53	3.65	-	3.73	3.81	3.93	-	3.96	4.05	4.18	-	4.17	4.26	4.40	-	4.34	4.44	4.58	-	4.49	4.59	4.75	-
			Amps	12.9	13.2	13.7	-	14.0	14.3	14.8	-	15.2	15.6	16.1	-	16.3	16.7	17.3	-	17.4	17.8	18.4	-	18.4	18.9	19.5	-
75		2000	Hi PR	205	221	233	-	230	248	261	-	262	282	297	-	298	321	339	-	335	361	381	-	370	399	421	-
			Lo PR	106	112	123	-	112	119	130	-	116	123	135	-	122	130	142	-	128	136	148	-	132	141	154	-
		1800	MBh	51.1	52.9	58.0	-	49.9	51.7	56.6	-	48.7	50.5	55.3	-	47.5	49.2	53.9	-	45.1	46.8	51.2	-	41.8	43.3	47.5	-
			S/T	0.67	0.56	0.39	-	0.70	0.58	0.40	-	0.71	0.60	0.41	-	0.74	0.62	0.43	-	0.77	0.64	0.44	-	0.77	0.64	0.45	-
		1600	DT	20	17	13	-	20	17	13	-	20	17	13	-	20	17	13	-	20	17	13	-	19	16	12	-
			kW	3.41	3.48	3.59	-	3.67	3.74	3.86	-	3.90	3.98	4.11	-	4.10	4.19	4.32	-	4.27	4.36	4.51	-	4.42	4.52	4.67	-
	75	2000	Amps	12.7	13.0	13.4	-	13.7	14.1	14.5	-	14.9	15.3	15.8	-	16.0	16.4	16.9	-	17.0	17.5	18.1	-	18.1	18.5	19.2	-
			Hi PR	201	216	228	-	225	243	256	-	256	276	291	-	292	314	332	-	329	354	373	-	363	391	412	-
		1800	Lo PR	104	110	120	-	109	116	127	-	114	121	132	-	119	127	139	-	125	133	145	-	130	138	150	-
			MBh	55.5	57.1	61.8	66.4	54.2	55.8	60.4	64.8	52.9	54.5	59.0	63.3	51.6	53.1	57.5	61.7	49.0	50.5	54.6	58.6	45.4	46.8	50.6	54.3
		1600	S/T	0.83	0.75	0.56	0.36	0.86	0.77	0.58	0.38	0.89	0.79	0.60	0.39	0.91	0.82	0.62	0.40	0.95	0.85	0.64	0.41	0.96	0.86	0.65	0.42
			DT	21	20	16	11	22	20	16	11	22	20	16	11	22	20	16	11	21	20	16	11	20	18	15	10
75		2000	kW	3.51	3.58	3.70	3.81	3.78	3.86	3.98	4.11	4.02	4.10	4.24	4.38	4.23	4.32	4.46	4.61	4.40	4.50	4.65	4.81	4.56	4.66	4.82	4.98
			Amps	13.1	13.4	13.9	14.4	14.2	14.6	15.1	15.6	15.5	15.9	16.4	17.0	16.6	17.0	17.5	18.2	17.6	18.1	18.7	19.4	18.7	19.2	19.8	20.6
		1800	Hi PR	209	224	237	247	234	252	266	277	266	286	302	315	303	326	344	359	341	367	387	404	377	405	428	447
			Lo PR	108	114	125	133	114	121	132	141	118	126	137	146	124	132	144	153	130	138	151	161	134	143	156	166
		1600	MBh	54.7	56.3	60.9	65.4	53.4	55.0	59.5	63.9	52.1	53.7	58.1	62.3	50.9	52.4	56.7	60.8	48.3	49.7	53.8	57.8	44.7	46.1	49.9	53.5
			S/T	0.80	0.71	0.54	0.35	0.83	0.74	0.56	0.36	0.85	0.76	0.57	0.37	0.88	0.78	0.59	0.38	0.91	0.81	0.62	0.40	0.92	0.82	0.62	0.40
	75	2000	DT	22	21	17	12	23	21	17	12	23	21	17	12	23	21	17	12	22	21	17	12	21	19	16	11
			kW	3.49	3.56	3.67	3.79	3.76	3.84	3.96	4.09	3.99	4.08	4.21	4.35	4.20	4.29	4.43	4.58	4.38	4.48	4.62	4.78	4.53	4.63	4.79	4.95
		1800	Amps	13.0	13.4	13.8	14.3	14.1	14.5	15.0	15.5	15.4	15.7	16.3	16.9	16.4	16.9	17.4	18.1	17.5	18.0	18.6	19.3	18.6	19.1	19.7	20.5
			Hi PR	207	223	235	245	232	250	264	275	264	284	300	313	301	324	342	357	339	364	385	401	374	403	425	443
		1600	Lo PR	107	114	124	132	113	120	131	140	117	125	136	145	123	131	143	152	129	137	150	160	134	142	155	165
			MBh	51.9	53.5	57.9	62.1	50.7	52.2	56.5	60.7	49.5	51.0	55.2	59.2	48.3	49.7	53.8	57.8	45.9	47.3	51.1	54.9	42.5	43.8	47.4	50.8
75		2000	S/T	0.76	0.68	0.52	0.33	0.79	0.71	0.54	0.35	0.81	0.73	0.55	0.35	0.84	0.75	0.57	0.37	0.87	0.78	0.59	0.38	0.88	0.79	0.59	0.38
			DT	23	21	17	12	23	21	17	12	23	21	17	12	23	21	18	12	23	21	17	12	21	20	16	11
		1800	kW	3.43	3.51	3.62	3.73	3.70	3.78	3.90	4.02	3.93	4.01	4.14	4.28	4.13	4.22	4.36	4.51	4.31	4.40	4.55	4.70	4.45	4.55	4.71	4.86
			Amps	12.8	13.1	13.5	14.1	13.9	14.2	14.7	15.2	15.1	15.5	16.0	16.6	16.1	16.5	17.1	17.8	17.2	17.6	18.2	18.9	18.2	18.7	19.3	20.1
		1600	Hi PR	203	218	231	241	228	245	259	270	259	279	294	307	295	317	335	350	332	357	377	393	367	395	417	435
			Lo PR	105	111	122	129	111	118	128	137	115	122	133	142	121	128	140	149	127	135	147	156	131	139	152	162

IDB: Entering Indoor Dry Bulb Temperature  
 High and low pressures are measured at the liquid and suction service valves.  
 Shaded area reflects ACCA (TVA) conditions  
 kW = Total system power  
 Amps = outdoor unit amps (compressor + fan)

EXPANDED COOLING DATA — ASZC180601B / CAPF4961D6\* +TXV / MBVC2000A — HIGH STAGE (CONT.)

IDB	AIRFLOW	OUTDOOR AMBIENT TEMPERATURE												ENTERING INDOOR WET BULB TEMPERATURE											
		65°F				75°F				85°F				95°F				105°F				115°F			
		59	63	67	71	59	63	67	71	59	63	67	71	59	63	67	71	59	63	67	71	59	63	67	71
80	MBh	56.5	57.7	61.6	65.9	55.2	56.4	60.2	64.4	53.8	55.0	58.8	62.8	52.5	53.7	57.3	61.3	49.9	51.0	54.5	58.2	46.2	47.2	50.5	53.9
	S/T	0.91	0.86	0.70	0.52	0.95	0.89	0.72	0.54	0.97	0.91	0.74	0.55	1.00	0.94	0.77	0.57	1.00	0.98	0.79	0.59	1.00	0.98	0.80	0.60
	DT	24	23	20	16	24	23	20	16	24	23	20	16	24	23	20	16	23	23	20	16	21	21	19	15
	KW	3.54	3.61	3.73	3.85	3.81	3.89	4.02	4.15	4.05	4.14	4.27	4.41	4.26	4.35	4.50	4.65	4.44	4.54	4.69	4.85	4.60	4.70	4.86	5.02
	Amps	13.2	13.6	14.0	14.6	14.3	14.7	15.2	15.8	15.6	16.0	16.5	17.2	16.7	17.1	17.7	18.4	17.8	18.3	18.9	19.6	18.9	19.4	20.0	20.8
	Hi PR	211	227	239	250	236	254	269	280	269	289	305	319	306	329	348	363	344	371	391	408	381	410	432	451
	Lo PR	109	116	126	134	115	122	133	142	119	127	139	148	125	133	146	155	131	140	152	162	136	144	158	168
	MBh	55.6	56.9	60.7	64.9	54.3	55.5	59.3	63.4	53.0	54.2	57.9	61.9	51.8	52.9	56.5	60.4	49.2	50.2	53.7	57.4	45.5	46.5	49.7	53.2
	S/T	0.88	0.82	0.67	0.50	0.91	0.85	0.69	0.52	0.93	0.87	0.71	0.53	0.96	0.90	0.73	0.55	1.00	0.93	0.76	0.57	1.00	0.94	0.77	0.57
	DT	25	24	21	17	25	24	21	17	25	24	21	17	25	24	21	17	25	24	21	17	23	22	19	16
KW	3.52	3.59	3.70	3.82	3.79	3.87	3.99	4.12	4.03	4.11	4.25	4.39	4.24	4.33	4.47	4.62	4.42	4.51	4.66	4.82	4.57	4.67	4.83	4.99	
Amps	13.2	13.5	13.9	14.5	14.2	14.6	15.1	15.7	15.5	15.9	16.4	17.1	16.6	17.0	17.6	18.3	17.7	18.1	18.8	19.5	18.8	19.2	19.9	20.7	
Hi PR	209	225	238	248	235	253	267	278	267	287	303	316	304	327	346	360	342	368	389	405	378	407	429	448	
Lo PR	108	115	125	133	114	121	132	141	118	126	138	147	124	132	145	154	130	139	151	161	135	143	157	167	
MBh	52.9	54.0	57.7	61.7	51.6	52.8	56.4	60.2	50.4	51.5	55.0	58.8	49.2	50.2	53.7	57.4	46.7	47.7	51.0	54.5	43.3	44.2	47.2	50.5	
S/T	0.84	0.79	0.64	0.48	0.87	0.82	0.66	0.50	0.89	0.84	0.68	0.51	0.92	0.86	0.70	0.52	0.95	0.90	0.73	0.54	0.96	0.90	0.73	0.55	
DT	25	24	21	17	26	25	22	17	26	25	22	17	26	25	22	17	26	25	22	17	24	23	20	16	
KW	3.46	3.53	3.65	3.76	3.73	3.81	3.93	4.06	3.96	4.05	4.18	4.31	4.17	4.26	4.40	4.54	4.34	4.44	4.58	4.74	4.49	4.59	4.75	4.91	
Amps	12.9	13.2	13.7	14.2	14.0	14.3	14.8	15.4	15.2	15.6	16.1	16.7	16.3	16.7	17.3	17.9	17.4	17.8	18.4	19.1	18.4	18.9	19.5	20.3	
Hi PR	205	221	233	243	230	248	261	273	262	282	297	310	298	321	339	353	335	361	381	397	370	399	421	439	
Lo PR	106	112	123	131	112	119	130	138	116	123	135	144	122	130	142	151	128	136	148	158	132	141	154	163	
85	MBh	57.5	58.6	61.3	65.4	56.1	57.2	59.9	63.9	54.8	55.8	58.5	62.4	53.4	54.5	57.1	60.9	50.8	51.8	54.2	57.8	47.0	47.9	50.2	53.6
	S/T	0.96	0.92	0.83	0.68	0.99	0.96	0.86	0.70	1.00	0.98	0.89	0.72	1.00	1.00	0.92	0.74	1.00	1.00	0.95	0.77	1.00	1.00	0.96	0.78
	DT	25	25	24	20	26	25	24	21	25	25	24	21	25	25	24	21	23	24	24	20	22	22	22	19
	KW	3.56	3.64	3.76	3.88	3.84	3.92	4.05	4.18	4.08	4.17	4.31	4.45	4.30	4.39	4.54	4.69	4.48	4.58	4.73	4.89	4.63	4.74	4.90	5.06
	Amps	13.4	13.7	14.2	14.7	14.5	14.8	15.3	15.9	15.8	16.2	16.7	17.3	16.9	17.3	17.9	18.6	18.0	18.4	19.1	19.8	19.1	19.6	20.2	21.0
	Hi PR	213	229	242	252	239	257	271	283	272	292	309	322	309	333	351	367	348	374	395	412	384	414	437	456
	Lo PR	110	117	127	136	116	123	135	143	120	128	140	149	127	135	147	157	133	141	154	164	137	146	159	170
	MBh	56.6	57.7	60.4	64.5	55.3	56.4	59.0	63.0	54.0	55.0	57.6	61.5	52.7	53.7	56.2	60.0	50.0	51.0	53.4	57.0	46.3	47.2	49.5	52.8
	S/T	0.92	0.89	0.80	0.65	0.95	0.92	0.83	0.67	0.98	0.94	0.85	0.69	1.00	0.97	0.88	0.71	1.00	1.00	0.91	0.74	1.00	1.00	0.92	0.74
	DT	27	26	25	21	27	26	25	22	27	26	25	22	27	27	25	22	26	26	26	21	24	24	23	20
KW	3.55	3.62	3.73	3.85	3.82	3.90	4.03	4.16	4.06	4.15	4.28	4.42	4.27	4.37	4.51	4.66	4.45	4.55	4.70	4.86	4.61	4.71	4.87	5.03	
Amps	13.3	13.6	14.1	14.6	14.4	14.7	15.2	15.8	15.7	16.0	16.6	17.2	16.8	17.2	17.8	18.5	17.9	18.3	18.9	19.7	19.0	19.4	20.1	20.9	
Hi PR	211	227	240	250	237	255	269	281	270	290	306	320	307	330	349	364	345	372	393	409	382	411	434	452	
Lo PR	109	116	127	135	115	122	134	142	120	127	139	148	126	134	146	155	132	140	153	163	136	145	158	168	
MBh	53.8	54.8	57.4	61.3	52.5	53.5	56.1	59.8	51.3	52.3	54.7	58.4	50.0	51.0	53.4	57.0	47.5	48.4	50.7	54.1	44.0	44.9	47.0	50.1	
S/T	0.88	0.85	0.77	0.62	0.91	0.88	0.79	0.64	0.93	0.90	0.81	0.66	0.96	0.93	0.84	0.68	1.00	0.97	0.87	0.71	1.00	0.97	0.88	0.71	
DT	27	27	25	22	27	27	26	22	28	27	26	22	28	27	26	22	27	27	27	22	25	25	24	21	
KW	3.49	3.56	3.67	3.79	3.76	3.84	3.96	4.09	3.99	4.08	4.21	4.35	4.20	4.29	4.43	4.58	4.38	4.47	4.62	4.78	4.53	4.63	4.79	4.95	
Amps	13.0	13.4	13.8	14.3	14.1	14.5	14.9	15.5	15.4	15.7	16.3	16.9	16.4	16.9	17.4	18.1	17.5	18.0	18.6	19.3	18.6	19.1	19.7	20.5	
Hi PR	207	223	235	245	232	250	264	275	264	284	300	313	301	324	342	357	339	364	385	401	374	403	425	443	
Lo PR	107	114	124	132	113	120	131	140	117	125	136	145	123	131	143	152	129	137	150	160	133	142	155	165	

IDB: Entering Indoor Dry Bulb Temperature  
 High and low pressures are measured at the liquid and suction service valves.  
 Shaded area reflects AHRI (TVA) conditions  
 kW = Total system power  
 Amps = outdoor unit amps (compressor + fan)

## EXPANDED HEATING DATA

ASZC180361A\* / CA\*F3642C6A\*+TXV/ MBE1600\*\*-1 — LOW STAGE

	OUTDOOR AMBIENT TEMPERATURE																	
	65	60	55	50	47	45	40	35	30	25	20	17	15	10	5	0	-5	-10
MBh	30.8	29.2	27.4	25.6	24.5	23.7	22.0	20.3	18.0	16.6	15.3	14.5	13.9	12.5	11.1	9.7	8.3	6.8
ΔT	33.5	31.8	29.9	27.9	26.7	25.9	24.0	22.1	19.6	18.1	16.7	15.8	15.2	13.6	12.1	10.5	9.0	7.4
kW	1.98	1.94	1.90	1.86	1.8	1.81	1.77	1.73	1.78	1.74	1.69	1.67	1.65	1.60	1.56	1.51	1.47	1.42
Amps	9.5	8.8	8.2	7.7	7.5	7.3	6.9	6.5	6.2	6.0	5.7	5.5	5.5	5.2	4.8	4.5	4.2	3.7
COP	4.54	4.39	4.23	4.04	3.91	3.83	3.64	3.44	2.96	2.81	2.65	2.54	2.48	2.28	2.08	1.87	1.64	1.39
EER	15.5	15.0	14.4	13.8	13.4	13.1	12.4	11.7	10.1	9.6	9.1	8.7	8.5	7.8	7.1	6.4	5.6	4.7

ASZC180361A\* / CA\*F3642C6A\*+TXV/ MBE1600\*\*-1 — HIGH STAGE

	OUTDOOR AMBIENT TEMPERATURE																	
	65	60	55	50	47	45	40	35	30	25	20	17	15	10	5	0	-5	-10
MBh	44.5	42.2	39.7	37.1	35.4	34.3	31.9	29.4	27.5	25.4	23.4	22.0	21.2	19.1	16.9	14.7	12.6	10.3
ΔT	33.0	31.2	29.4	27.5	26.2	25.4	23.6	21.8	20.4	18.8	17.3	16.3	15.7	14.1	12.5	10.9	9.3	7.6
kW	2.81	2.75	2.69	2.63	2.6	2.57	2.52	2.46	2.43	2.37	2.32	2.28	2.26	2.20	2.14	2.08	2.02	1.97
Amps	12.8	11.8	11.1	10.4	10.0	9.8	9.2	8.7	8.3	8.0	7.6	7.4	7.3	6.9	6.4	6.0	5.5	4.9
COP	4.64	4.49	4.32	4.12	3.99	3.90	3.71	3.50	3.30	3.13	2.95	2.83	2.75	2.54	2.31	2.07	1.82	1.53
EER	15.9	15.3	14.8	14.1	13.6	13.3	12.7	12.0	11.3	10.7	10.1	9.7	9.4	8.7	7.9	7.1	6.2	5.2

ASZC180481A\* / CA\*F4860\*6A\*+TXV/ MBE2000\*\*- — LOW STAGE

	OUTDOOR AMBIENT TEMPERATURE																	
	65	60	55	50	47	45	40	35	30	25	20	17	15	10	5	0	-5	-10
MBh	43.8	41.4	39.0	36.5	34.8	33.7	31.3	28.9	27.0	25.0	23.0	21.7	20.9	18.7	16.6	14.5	12.4	10.1
ΔT	33.8	32.0	30.1	28.1	26.9	26.0	24.2	22.3	20.9	19.3	17.7	16.7	16.1	14.5	12.8	11.2	9.5	7.8
kW	2.67	2.62	2.56	2.50	2.5	2.44	2.39	2.33	2.44	2.38	2.32	2.28	2.26	2.19	2.13	2.07	2.01	1.95
Amps	12.7	11.7	10.9	10.2	9.8	9.6	9.0	8.5	8.1	7.7	7.2	7.0	6.9	6.5	6.0	5.6	5.1	4.5
COP	4.79	4.63	4.46	4.27	4.13	4.04	3.84	3.63	3.24	3.07	2.90	2.78	2.71	2.50	2.28	2.05	1.80	1.52
EER	16.4	15.8	15.2	14.6	14.1	13.8	13.1	12.4	11.1	10.5	9.9	9.5	9.3	8.5	7.8	7.0	6.2	5.2

ASZC180481A\* / CA\*F4860\*6A\*+TXV/ MBE2000\*\*-1 — HIGH STAGE

	OUTDOOR AMBIENT TEMPERATURE																	
	65	60	55	50	47	45	40	35	30	25	20	17	15	10	5	0	-5	-10
MBh	62.2	58.9	55.4	51.8	49.5	48.0	44.6	41.1	38.9	35.9	33.0	31.2	30.0	27.0	23.9	20.8	17.8	14.6
ΔT	32.9	31.2	29.3	27.4	26.2	25.4	23.6	21.7	20.6	19.0	17.5	16.5	15.9	14.3	12.6	11.0	9.4	7.7
kW	3.80	3.72	3.64	3.56	3.5	3.49	3.41	3.33	3.28	3.20	3.12	3.07	3.04	2.96	2.89	2.81	2.73	2.66
Amps	17.0	15.7	14.7	13.8	13.2	13.0	12.2	11.5	11.0	10.5	10.0	9.7	9.6	9.1	8.4	7.9	7.2	6.4
COP	4.80	4.64	4.46	4.26	4.12	4.03	3.82	3.61	3.47	3.29	3.10	2.97	2.89	2.66	2.42	2.17	1.90	1.61
EER	16.4	15.8	15.2	14.5	14.1	13.8	13.1	12.3	11.9	11.2	10.6	10.2	9.9	9.1	8.3	7.4	6.5	5.5

Calculations are based on nominal CFM and 70 °F indoor dry bulb.

Amps = Outdoor unit amps (comp.+fan)

Note: Shaded area is AHRI Rating Conditions at 47°F outdoor ambient temperature

kW = Total system power

## EXPANDED HEATING DATA (CONT.)

### ASZC180601B\* / CAPF4961D6 / MBVC2000A — LOW STAGE

	OUTDOOR AMBIENT TEMPERATURE																	
	65	60	55	50	47	45	40	35	30	25	20	17	15	10	5	0	-5	-10
MBh	49.8	47.1	44.4	41.5	39.6	38.4	35.6	32.9	29.8	27.5	25.3	23.9	23.0	20.7	18.3	16.0	13.6	11.2
T/R	38.4	36.4	34.2	32.0	30.6	29.6	27.5	25.4	23.0	21.2	19.5	18.5	17.8	15.9	14.1	12.3	10.5	8.6
kW	3.41	3.33	3.26	3.19	3.1	3.12	3.05	2.97	3.37	3.28	3.20	3.15	3.11	3.03	2.94	2.86	2.77	2.69
Amps	16.8	15.6	14.6	13.7	13.2	12.9	12.2	11.6	11.1	10.6	10.1	9.8	9.7	9.2	8.6	8.0	7.4	6.7
COP	4.28	4.14	3.98	3.81	3.68	3.60	3.42	3.24	2.59	2.45	2.32	2.22	2.17	2.00	1.82	1.64	1.44	1.22
EER	14.6	14.1	13.6	13.0	12.6	12.3	11.7	11.1	8.8	8.4	7.9	7.6	7.4	6.8	6.2	5.6	4.9	4.2

### ASZC180601B\* / CAPF4961D6 / MBVC2000A — HIGH STAGE

	OUTDOOR AMBIENT TEMPERATURE																	
	65	60	55	50	47	45	40	35	30	25	20	17	15	10	5	0	-5	-10
MBh	71.0	67.2	63.3	59.2	56.5	54.7	50.9	46.9	43.6	40.3	37.1	35.0	33.7	30.2	26.8	23.4	20.0	16.3
T/R	36.5	34.6	32.6	30.4	29.1	28.2	26.2	24.1	22.4	20.7	19.1	18.0	17.3	15.6	13.8	12.0	10.3	8.4
kW	4.57	4.48	4.39	4.30	4.2	4.21	4.12	4.03	4.52	4.41	4.31	4.24	4.20	4.09	3.99	3.88	3.77	3.67
Amps	21.4	19.8	18.5	17.3	16.7	16.4	15.4	14.6	14.0	13.3	12.6	12.3	12.2	11.5	10.7	10.1	9.3	8.3
COP	4.55	4.39	4.22	4.03	3.90	3.81	3.61	3.41	2.82	2.67	2.52	2.41	2.35	2.16	1.97	1.76	1.55	1.30
EER	15.5	15.0	14.4	13.8	13.3	13.0	12.3	11.6	9.6	9.1	8.6	8.2	8.0	7.4	6.7	6.0	5.3	4.5

Calculations are based on nominal CFM and 70 °F indoor dry bulb.

Amps = Outdoor unit amps (comp.+fan)

Note: Shaded area is AHRI Rating Conditions at 47°F outdoor ambient temperature

kW = Total system power

AHRI RATINGS

OUTDOOR UNIT	INDOOR UNITS		FURNACES	COOLING CAPACITY (BTU/H)			TVR RATINGS <sup>3</sup>			HEATING CAPACITY (BTU/H)		AHRI #	
	COILS/AIR HANDLERS			TOTAL	SEER <sup>1</sup>	EER <sup>2</sup>	TOTAL	SENS.	HI (47F)	HSPF <sup>4</sup>	LOW (17F)		
ASZC18 0361A *	CHPF4860D6D*+TXV		A*V81155C*	34,600	17.50	12.50	32,000	25,900	35,000	9.3	20,000	3610796	
	CHPF4860D6D*+TXV		A*VC90704CXA *	34,600	17.50	12.50	32,000	25,900	35,000	9.3	20,000	3610798	
	CHPF4860D6D*+MIBE2000**-.1B*+TXV			35,000	18.00	13.00	32,400	26,200	35,000	9.3	20,000	3610869	
	CHPF4860D6D*+TXV		A*VC90905DXA *	35,000	18.00	13.00	32,400	26,200	35,000	9.3	20,000	3610872	
	CHPF4860D6D*+TXV		A*VC951155DXA *	35,000	18.00	13.00	32,400	26,200	35,000	9.3	20,000	3610874	
	CA*F4961*6D*+MIBVC2000**-.1A*+TXV			35,000	18.00	13.00	32,400	26,200	35,000	9.3	20,400	4431605	
	CA*F4961*6D*+TXV		A*VC80704BXA *	34,600	17.50	12.50	32,000	25,900	35,000	9.3	20,000	4431606	
	CA*F3743*6D*+TXV		G*VC950905DXA *	35,000	18.00	13.00	32,400	26,200	35,000	9.3	20,400	4415355	
	CA*F3743*6D*+TXV		A*VC950714CXA *	34,600	17.50	12.50	32,000	25,900	35,000	9.3	20,000	4586541	
	CA*F4961*6D*+TXV		A*VM961155DXA *	35,000	18.00	13.00	32,400	26,200	35,000	9.3	20,000	4654826	
	CA*F3743*6D*+TXV		A*VC951155DXA *	35,000	18.00	13.00	32,400	26,200	35,000	9.3	20,400	4415350	
	CA*F3743*6D*+TXV		G*VC950905CXA *	35,000	17.50	12.50	32,400	26,200	35,000	9.3	20,400	4415354	
	CA*F3743*6D*+TXV		G*VC950704CXA *	34,600	17.50	12.50	32,000	25,900	35,000	9.3	20,000	4415352	
	CA*F3743*6D*+TXV		A*VM960603BXA *	34,600	17.50	12.50	32,000	25,900	35,000	9.3	20,000	4655028	
	CA*F4961*6D*+TXV		A*VM960603BXA *	34,600	17.50	12.50	32,000	25,900	35,000	9.3	20,000	4655031	
	CA*F3743*6D*+MIBVC2000**-.1A*+TXV			35,000	18.00	13.00	32,400	26,200	34,800	35,000	9.3	20,400	4415362
	CA*F4961*6D*+TXV		A*VC950915DXA *	35,000	18.00	12.80	32,400	26,200	35,000	9.3	20,000	4431616	
	CA*F3743*6D*+TXV		A*VC950453BXA *	34,600	17.50	12.50	32,000	25,900	35,000	9.3	20,000	4415363	
	CA*F4961*6D*+TXV		A*VC950714CXA *	34,600	17.50	12.50	32,000	25,900	35,000	9.3	20,000	4431613	
	CHPF4860D6D*+TXV		G*VC950915DXA *	35,000	18.00	12.80	32,400	26,200	35,000	9.3	20,400	4415356	
CA*F4961*6D*+TXV		A*VC80905CXA *	34,600	17.50	12.50	32,000	25,900	35,000	9.3	20,000	4431607		
CA*F3743*6D*+TXV		G*VC950714CXA *	34,600	17.50	12.50	32,000	25,900	35,000	9.3	20,000	4415353		
CA*F4961*6D*+TXV		A*VC950453BXA *	34,600	17.50	12.50	32,000	25,900	35,000	9.3	20,000	4431611		
CA*F4961*6D*+TXV		A*VC951155DXA *	35,000	18.00	13.00	32,400	26,200	35,000	9.3	20,000	4431617		
CHPF4860D6D*+TXV		A*VC950905CXA *	35,000	17.50	12.50	32,400	26,200	35,000	9.3	20,000	4185127		
CA*F4961*6D*+TXV		G*VC950915DXA *	35,000	18.00	12.80	32,400	26,200	35,000	9.3	20,000	4594928		
CA*F4961*6D*+TXV		A*VC81155CXA *	34,600	17.50	12.50	32,000	25,900	35,000	9.3	20,000	4431608		
CHPF4860D6D*+TXV		A*VC80905CXA *	34,600	17.50	12.50	32,000	25,900	35,000	9.3	20,000	4362385		
CA*F3743*6D*+TXV		G*VM960805CXA *	35,000	17.50	12.50	32,400	26,200	35,000	9.3	20,400	4654951		
CHPF4860D6D*+TXV		A*VM960805DXA *	35,000	18.00	12.80	32,400	26,200	35,000	9.3	20,000	4655146		
CA*F3743*6D*+TXV		G*VM961155DXA *	35,000	18.00	13.00	32,400	26,200	35,000	9.3	20,400	4654799		
CA*F3743*6D*+TXV		A*VM960604CXA *	34,600	17.50	12.50	32,000	25,900	35,000	9.3	20,000	4655068		
CA*F3743*6D*+TXV		G*VM960805DXA *	35,000	18.00	12.80	32,400	26,200	35,000	9.3	20,400	4655104		
CHPF4860D6D*+TXV		A*VM960604CXA *	34,600	17.50	12.50	32,000	25,900	35,000	9.3	20,000	4655090		
CA*F4860*6D*+TXV		A*VC80905CXA *	35,000	17.50	12.50	32,400	26,200	35,000	9.3	20,000	4393020		
CA*F3743*6D*+TXV		A*VC950905CXA *	35,000	17.50	12.50	32,400	26,200	35,000	9.3	20,400	4415347		
CA*F3743*6D*+TXV		A*VC90905DXA *	35,000	18.00	13.00	32,400	26,200	35,000	9.3	20,400	4415346		
CA*F4961*6D*+TXV		A*VC950905DXA *	35,000	18.00	13.00	32,400	26,200	35,000	9.3	20,000	4431615		
CA*F4961*6D*+TXV		A*VC950704CXA *	34,600	17.50	12.50	32,000	25,900	35,000	9.3	20,000	4431612		
CHPF4860D6D*+TXV		A*VM960805CXA *	35,000	17.50	12.50	32,400	26,200	35,000	9.3	20,000	4654988		
CHPF4860D6D*+TXV		A*VM961005DXA *	35,000	18.00	13.00	32,400	26,200	35,000	9.3	20,000	4654918		
CA*F3743*6D*+MIBVC1600**-.1A*+TXV			35,000	18.00	13.00	32,400	26,200	35,000	9.5	20,400	4415344		
AVPTC426014A *			35,000	18.00	13.00	32,400	26,200	35,000	9.3	20,400	4431381		
CA*F4961*6D*+TXV		A*VC90905DXA *	35,000	18.00	13.00	32,400	26,200	35,000	9.3	20,000	4431610		

See Notes on Page 22.

AHRI RATINGS (CONT.)

OUTDOOR UNIT	INDOOR UNITS		FURNACES	COOLING CAPACITY (BTU/H)			HEATING CAPACITY (BTU/H)			AHRI #
	COILS/AIR HANDLERS			TOTAL	SENS.	SEER <sup>1</sup>	EER <sup>2</sup>	HI (47F)	HSPF <sup>4</sup>	
ASZC18 0361A* (cont.)	CA*F3743*6D*+TXV	A*VC81155CXA*	A*VC81155CXA*	34,600	26,300	17.50	12.50	35,000	9.3	20,000
	CA*F4961*6D*+TXV	A*VC950905CXA*	A*VC950905CXA*	35,000	26,600	17.50	12.50	35,000	9.3	20,000
	CA*F4961*6D*+MBVC1600**-.1A**+TXV	A*VC950905CXA*	A*VC950905CXA*	35,000	26,600	18.00	13.00	35,000	9.5	20,000
	CSCF4860N6D*+TXV	A*VC950905DXA*	A*VC950905DXA*	35,000	26,600	17.50	12.50	35,000	9.3	20,000
	CSCF3642N6D*+TXV	A*VC950453BXA*	A*VC950453BXA*	34,600	26,300	17.50	12.50	35,000	9.3	20,000
	CA*F3743*6D*+TXV	A*VM960805CXA*	A*VM960805CXA*	35,000	26,600	17.50	12.50	35,000	9.3	20,400
	CA*F4961*6D*+TXV	A*VM960805CXA*	A*VM960805CXA*	35,000	26,600	17.50	12.50	35,000	9.3	20,400
	CA*F3743*6D*+TXV	G*VM961005DXA*	G*VM961005DXA*	35,000	26,600	18.00	13.00	35,000	9.3	20,400
	CSCF3642N6D*+TXV	A*VC80905CXA*	A*VC80905CXA*	34,600	26,300	17.50	12.50	35,000	9.3	20,400
	CSCF4860N6D*+TXV	A*VC80905CXA*	A*VC80905CXA*	34,600	26,300	17.50	12.50	35,000	9.3	20,000
	CSCF4860N6D*+TXV	A*VC950905CXA*	A*VC950905CXA*	35,000	26,600	17.50	12.50	35,000	9.3	20,000
	CSCF4860N6D*+TXV	A*VC950905CXA*	A*VC950905CXA*	35,000	26,600	17.50	12.50	35,000	9.3	20,000
	CSCF3642N6D*+TXV	A*VC951155DXA*	A*VC951155DXA*	35,000	26,600	18.00	13.00	35,000	9.3	20,400
	CA*F3743*6D*+TXV	A*VM961155DXA*	A*VM961155DXA*	35,000	26,600	18.00	13.00	35,000	9.3	20,400
	CA*F4961*6D*+TXV	A*VM960604CXA*	A*VM960604CXA*	34,600	26,300	17.50	12.50	35,000	9.3	20,000
	CSCF4860N6D*+TXV	A*VC950453BXA*	A*VC950453BXA*	34,600	26,300	17.50	12.50	35,000	9.3	20,000
	CSCF3642N6D*+TXV	A*VC950905DXA*	A*VC950905DXA*	35,000	26,600	18.00	13.00	35,000	9.3	20,400
	CSCF3642N6D*+TXV	A*VC950905CXA*	A*VC950905CXA*	35,000	26,600	17.50	12.50	35,000	9.3	20,400
	CSCF4860N6D*+TXV	A*VC950704CXA*	A*VC950704CXA*	34,600	26,300	17.50	12.50	35,000	9.3	20,000
	CA*F4961*6D*+TXV	GDVC80805C*A*	GDVC80805C*A*	34,600	26,300	17.50	12.50	35,000	9.3	20,000
CHPF3743C6B*+TXV	G*VC81005C*A*	G*VC81005C*A*	34,600	26,300	17.50	12.50	35,000	9.3	20,000	
CHPF4860D6D*+TXV	G*VC81005C*A*	G*VC81005C*A*	34,600	26,300	17.50	12.50	35,000	9.3	20,000	
CA*F4961*6D*+TXV	G*VC81005C*A*	G*VC81005C*A*	34,600	26,300	17.50	12.50	35,000	9.3	20,000	
CHPF3743C6B*+TXV	G*VC80805C*A*	G*VC80805C*A*	34,600	26,300	17.50	12.50	35,000	9.3	20,000	
CHPF3743D6B*+TXV	GDVC80805C*A*	GDVC80805C*A*	34,600	26,300	17.50	12.50	35,000	9.3	20,000	
CA*F4961*6D*+TXV	GDVC81005C*A*	GDVC81005C*A*	34,600	26,300	17.50	12.50	35,000	9.3	20,000	
CA*F4961*6D*+TXV	G*VC80604B*A*	G*VC80604B*A*	34,600	26,300	17.50	12.50	35,000	9.3	20,000	
CA*F4961*6D*+TXV	G*VC80805C*A*	G*VC80805C*A*	34,600	26,300	17.50	12.50	35,000	9.3	20,000	
CA*F3743*6D*+TXV	GDVC81005C*A*	GDVC81005C*A*	34,600	26,300	17.50	12.50	35,000	9.3	20,000	
CHPF3743D6B*+TXV	G*VC81005C*A*	G*VC81005C*A*	34,600	26,300	17.50	12.50	35,000	9.3	20,000	
CHPF3743D6B*+TXV	GDVC80805C*A*	GDVC80805C*A*	34,600	26,300	17.50	12.50	35,000	9.3	20,000	
CA*F4860*6D*+TXV	GDVC80805C*A*	GDVC80805C*A*	35,000	26,600	17.50	12.50	35,000	9.3	20,000	
CHPF4860D6D*+TXV	GDVC81005C*A*	GDVC81005C*A*	34,600	26,300	17.50	12.50	35,000	9.3	20,000	
CHPF4860D6D*+TXV	G*VC80805C*A*	G*VC80805C*A*	34,600	26,300	17.50	12.50	35,000	9.3	20,000	
CHPF3743D6B*+TXV	G*VC80604B*A*	G*VC80604B*A*	34,600	26,300	17.50	12.50	35,000	9.3	20,000	
CA*F4860*6D*+TXV	G*VC80805C*A*	G*VC80805C*A*	35,000	26,600	17.50	12.50	35,000	9.3	20,000	
CHPF4860D6D*+TXV	G*VC81005C*A*	G*VC81005C*A*	34,600	26,300	17.50	12.50	35,000	9.3	20,000	
CHPF4860D6D*+TXV	A*VC950905DXA*	A*VC950905DXA*	35,000	26,600	18.00	13.00	35,000	9.3	20,000	
CHPF4860D6D*+MBVC2000**-.1A**+TXV	A*VC950915DXA*	A*VC950915DXA*	35,000	26,600	18.00	13.00	35,000	9.3	20,000	
CA*F3743*6D*+TXV	G*VC90704CXA*	G*VC90704CXA*	34,600	26,300	17.50	12.50	35,000	9.0	20,400	
CA*F3743*6D*+TXV	A*VC90704CXA*	A*VC90704CXA*	34,600	26,300	17.50	12.50	35,000	9.3	20,400	
CA*F4961*6D*+TXV	A*VC90704CXA*	A*VC90704CXA*	34,600	26,300	18.00	13.00	35,000	9.3	20,400	
AVPTC131714*			35,000	26,600	17.50	12.50	35,000	9.3	20,400	
CHPF4860D6D*+TXV	A*VC950704CXA*	A*VC950704CXA*	34,600	26,300	17.50	12.50	35,000	9.3	20,000	

See Notes on Page 22.

AHRI RATINGS (CONT.)

OUTDOOR UNIT	INDOOR UNITS		FURNACES		COOLING CAPACITY (BTU/H)		SEER <sup>1</sup>		EER <sup>2</sup>		TVR RATINGS <sup>3</sup>		HEATING CAPACITY (BTU/H)		AHRI #
	COILS/AIR HANDLERS		TOTAL	SENS.	SEER <sup>1</sup>	EER <sup>2</sup>	TOTAL	SENS.	Hi (47F)	HSPF <sup>4</sup>	Low (47F)				
ASZC18 0481A*	CA*F3743*6D*+TXV	A*VC950704CXA*	34,600	26,300	17.50	12.50	32,000	25,900	35,000	9.3	20,000	4476735			
	AEPF426016C*+TXV	A*VM961005DXA*	35,000	26,600	18.00	13.00	32,400	26,200	35,000	9.3	20,400	3610828			
	CA*F3743*6D*+TXV	A*VM961005DXA*	35,000	26,600	18.00	13.00	32,400	26,200	35,000	9.3	20,400	4654875			
	CA*F4961*6D*+TXV	A*VM961005DXA*	35,000	26,600	18.00	13.00	32,400	26,200	35,000	9.3	20,000	4654905			
	CA*F4961*6D*+TXV	A*VM960805DXA*	35,000	26,600	18.00	12.80	32,400	26,200	35,000	9.3	20,000	4655131			
	CHPF4860D6D*+TXV	A*VC81155CXA*	34,600	26,300	17.50	12.50	32,000	25,900	35,000	9.3	20,000	3642837			
	CHPF4860N6D*+TXV	A*VC951155DXA*	35,000	26,600	17.50	13.00	32,400	26,200	35,000	9.3	20,000	4770621			
	CSCF4860N6D*+TXV	A*VC81155CXA*	34,600	26,300	17.50	12.50	32,000	25,900	35,000	9.3	20,000	4770616			
	CSCF3642N6D*+TXV	A*VC81155CXA*	34,600	26,300	17.50	12.50	32,000	25,900	35,000	9.3	20,400	4770610			
	CHPF3743C6B*+TXV	G*VC81005C*A*	34,600	26,300	17.50	12.50	32,000	25,900	35,000	9.3	20,000	4888213			
	CHPF3743D6B*+TXV	GDV81005C*A*	34,600	26,300	17.50	12.50	32,000	25,900	35,000	9.3	20,000	4888219			
	CA*F3743*6D*+TXV	A*VC950905DXA*	35,000	26,600	18.00	13.00	32,400	26,200	35,000	9.3	20,400	4415348			
	CA*F3743*6D*+TXV	G*VC951155DXA*	35,000	26,600	18.00	13.00	32,400	26,200	35,000	9.3	20,400	4415357			
	CA*F3743*6D*+TXV	A*VM960805DXA*	35,000	26,600	18.00	12.80	32,400	26,200	35,000	9.3	20,400	4655105			
	CHPF4860D6D*+TXV	A*VM961155DXA*	35,000	26,600	18.00	13.00	32,400	26,200	35,000	9.3	20,000	4654846			
	CA*F3743*6D*+TXV	G*VM960604CXA*	34,600	26,300	17.50	12.50	32,000	25,900	35,000	9.3	20,000	4655067			
	CHPF4860D6D*+TXV	G*VC80805C*A*	34,600	26,300	17.50	12.50	32,000	25,900	35,000	9.3	20,000	4888220			
	CHPF4860D6D*+MBVC2000*-1A*+TXV		47,500	35,600	18.00	13.00	43,900	35,100	47,500	9.5	29,600	3611082			
	CHPF4860D6D*+TXV	A*VC90905DXA*	47,000	35,300	17.50	12.50	43,500	34,800	47,000	9.3	29,000	3610927			
	CHPF4860D6D*+TXV	A*VC950704CXA*	47,000	35,300	17.50	12.50	43,500	34,800	47,000	9.3	29,000	3610928			
CHPF4860D6D*+MBE2000*-1B*+TXV		47,500	35,600	18.00	13.00	43,900	35,100	47,500	9.5	29,600	3610961				
CHPF4860D6D*+TXV	A*VC90704CXA*	47,000	35,300	17.50	12.50	43,500	34,800	47,000	9.3	29,000	3610926				
CHPF4860D6D*+TXV	A*VC951155DXA*	47,000	35,300	17.75	12.50	43,500	34,800	47,000	9.3	29,000	3610930				
CHPF4860D6D*+TXV	A*VC80905CXA*	47,000	35,300	17.50	12.50	43,500	34,800	47,000	9.3	29,000	3642885				
CHPF4860D6D*+TXV	A*V81155C**	47,000	35,300	17.50	12.50	43,500	34,800	47,000	9.3	29,000	3610922				
CHPF4860D6D*+TXV	A*VC81155CXA*	47,000	35,300	17.00	12.20	43,500	34,800	47,000	9.3	29,000	3707097				
CA*F4961*6D*+TXV	A*VC90905DXA*	47,000	35,300	17.50	12.50	43,500	34,800	47,000	9.3	29,000	4431622				
CA*F4961*6D*+TXV	A*VC80905CXA*	47,000	35,300	17.50	12.50	43,500	34,800	47,000	9.3	29,000	4431619				
AVPTC426014A*		47,000	35,300	17.50	12.50	43,500	34,800	47,000	9.3	29,000	4431382				
CA*F4961*6D*+TXV	A*VM960805CXA*	47,000	35,300	17.50	12.50	43,500	34,800	47,000	9.3	29,000	4654969				
CA*F4961*6D*+TXV	G*VM960805CXA*	47,000	35,300	17.50	12.50	43,500	34,800	47,000	9.3	29,000	4654971				
CA*F4961*6D*+TXV	A*VM960805DXA*	47,000	35,300	17.50	12.50	43,500	34,800	47,000	9.3	29,000	4655128				
CA*F4961*6D*+TXV	A*VC950915DXA*	47,000	35,300	17.50	12.50	43,500	34,800	47,000	9.3	29,000	4431626				
CA*F4961*6D*+TXV	A*VC81155CXA*	47,000	35,300	17.00	12.20	43,500	34,800	47,000	9.3	29,000	4431620				
CA*F4961*6D*+TXV	G*VC950915DXA*	47,000	35,300	17.50	12.50	43,500	34,800	47,000	9.3	29,000	4431618				
CA*F4961*6D*+TXV	A*VM961005DXA*	47,000	35,300	17.50	12.50	43,500	34,800	47,000	9.3	29,000	4431630				
CA*F4961*6D*+TXV	A*VC950905CXA*	47,000	35,300	17.50	12.50	43,500	34,800	47,000	9.3	29,000	4431624				
CHPF4860D6D*+TXV	G*VM961005DXA*	47,000	35,300	17.75	12.50	43,500	34,800	47,000	9.3	29,000	4654906				
CSCF4860N6D*+TXV	A*VM961005DXA*	47,000	35,300	17.75	12.50	43,500	34,800	47,000	9.3	29,000	4654923				
CSCF4860N6D*+TXV	A*VC950905DXA*	47,000	35,300	16.50	12.50	43,500	34,800	47,000	9.3	29,000	4770626				
CA*F4961*6D*+TXV	A*VC950905DXA*	47,000	35,300	17.50	12.50	43,500	34,800	47,000	9.3	29,000	4431625				
CHPF4860D6D*+TXV	A*VM960805DXA*	47,000	35,300	17.50	12.50	43,500	34,800	47,000	9.3	29,000	4655144				
CA*F4961*6D*+TXV	A*VM961155DXA*	47,000	35,300	17.75	12.50	43,500	34,800	47,000	9.3	29,000	4654827				
CA*F4961*6D*+TXV	A*VM961005DXA*	47,000	35,300	17.75	12.50	43,500	34,800	47,000	9.3	29,000	4654902				

See Notes on Page 22.

AHRI RATINGS (CONT.)

OUTDOOR UNIT	INDOOR UNITS		COOLING CAPACITY (BTU/H)			HEATING CAPACITY (BTU/H)			AHRI #
	COILS/AIR HANDLERS	FURNACES	TOTAL	SEER <sup>1</sup>	EER <sup>2</sup>	Hi (47F)	SENS.	Hi (47F)	
ASZC18 0481A* (cont.)	CHPF4860D6D*+TXV	A*VM961155DXA*	47,000	17.75	12.50	47,000	34,800	47,000	4654847
	CA*F4961*6D*+MBVC2000**_1A*+TXV		47,500	18.00	13.00	47,500	35,100	47,500	4612963
	CA*F4961*6D*+TXV	G*VC950905CXA*	47,000	17.50	12.50	47,000	34,800	47,000	4431628
	CA*F4961*6D*+TXV	A*VC90704CXA*	47,000	17.50	12.50	47,000	34,800	47,000	4431621
	CSCF4860D6D*+TXV	A*VC80905CXA*	47,000	17.00	12.50	47,000	34,800	47,000	4770622
	CA*F4961*6D*+TXV	G*VM961155DXA*	47,000	17.75	12.50	47,000	34,800	47,000	4654828
	CSCF4860D6D*+TXV	A*VC81155CXA*	47,000	16.50	12.20	47,000	34,800	47,000	4770623
	CHPF4860D6D*+TXV	A*VM960805CXA*	47,000	17.50	12.50	47,000	34,800	47,000	4654983
	CSCF4860N6D*+TXV	A*VC950704CXA*	47,000	16.50	12.50	47,000	34,800	47,000	4770624
	CSCF4860N6D*+TXV	A*VC950905CXA*	47,000	16.50	12.50	47,000	34,800	47,000	4770625
	CHPF4860D6D*+TXV	G*VC81005C*A*	47,000	17.00	12.50	47,000	34,800	47,000	4888243
	CA*F4961*6D*+TXV	G*VC80805C*A*	47,000	17.50	12.50	47,000	34,800	47,000	4888238
	CHPF4860D6D*+TXV	G*VC80805C*A*	47,000	17.50	12.50	47,000	34,800	47,000	4888240
	CHPF4860D6D*+TXV	A*VC950905DXA*	47,000	17.50	12.50	47,000	34,800	47,000	3610929
	CHPF4860D6D*+TXV	A*VC950905CXA*	47,000	17.50	12.50	47,000	34,800	47,000	4185132
	CA*F4961*6D*+TXV	G*VC950905DXA*	47,000	17.50	12.50	47,000	34,800	47,000	4431629
	CA*F4961*6D*+TXV	G*VC951155DXA*	47,000	17.75	12.50	47,000	34,800	47,000	4431631
	AEPF426016C*+TXV		47,000	17.50	12.50	47,000	34,800	47,000	3610904
	CA*F4961*6D*+TXV	G*VM960805DXA*	47,000	17.50	12.50	47,000	34,800	47,000	4655129
	CHPF4860D6D*+TXV	G*VC81005C*A*	47,000	17.00	12.20	47,000	34,800	47,000	4888241
CA*F4961*6D*+TXV	G*VC81005C*A*	47,000	17.00	12.20	47,000	34,800	47,000	4888237	
CA*F4961*6D*+TXV	A*VC951155DXA*	47,000	17.75	12.50	47,000	34,800	47,000	4431627	
CA*F4961*6D*+TXV	A*VC950704CXA*	47,000	17.50	12.50	47,000	34,800	47,000	4431623	
CSCF4860N6D*+TXV	A*VC951155DXA*	47,000	16.75	12.50	47,000	34,800	47,000	4770627	
CHPF4860D6D*+TXV	G*VC80805C*A*	47,000	17.50	12.50	47,000	34,800	47,000	4888242	
CA*F4961*6D*+TXV	G*VC80805C*A*	47,000	17.50	12.50	47,000	34,800	47,000	4888236	
CA*F4961*6D*+TXV	G*VC81005C*A*	47,000	17.00	12.20	47,000	34,800	47,000	4888239	
ASZC18 0601B*	CHPF4860D6D*+TXV	G*E80905C**	55,500	16.80	12.60	55,500	39,500	55,500	4236623
	CHPF4860D6D*+TXV	A*VC951155DXA*	55,000	16.40	12.10	55,000	39,200	56,000	4236609
	CHPF4860D6D*+MBVC2000**_1A*+TXV		55,500	17.00	12.80	55,500	39,500	55,500	4236620
	CHPF4860D6D*+TXV	A*VC81155CXA*	55,000	16.90	12.40	50,900	39,200	56,000	4236618
	CHPF4860D6D*+TXV	G*E81155C**	55,000	16.60	12.20	50,900	39,200	56,000	4236626
	CA*F4961*6D*+TXV	A*VC950915DXA*	55,000	16.60	12.10	50,900	39,200	56,000	4431647
	CHPF4860D6D*+TXV	A*VC80905CXA*	55,500	16.90	12.60	55,500	39,500	55,500	4236615
	CA*F4961*6D*+TXV	G*VC80905CXA*	55,500	16.70	12.50	55,500	39,500	55,500	4431651
	CA*F4961*6D*+TXV	A*VC950905CXA*	55,000	16.30	12.00	50,900	39,200	56,500	4431645
	CA*F4961*6D*+TXV	G*VC81155CXA*	55,500	16.70	12.30	51,300	39,500	56,000	4431652
	CHPF4860D6D*+TXV	G*VC81155CXA*	55,000	16.90	12.40	50,900	39,200	56,000	4236632
	CA*F4961*6D*+TXV	A*VC81155CXA*	55,500	16.70	12.30	51,300	39,500	56,000	4431644
	CA*F4961*6D*+TXV	A*VM961155DXA*	55,500	16.30	12.20	51,300	39,500	56,000	4654829
	CA*F4961*6D*+TXV	A*VM960805CXA*	55,000	16.30	12.00	50,900	39,200	56,500	4654972
	CHPF4860D6D*+TXV	A*VM960805CXA*	55,000	16.40	12.00	50,900	39,200	56,000	4654989
	AVPTC426014A*		56,000	17.00	12.50	51,800	39,900	56,000	4431383
	CA*F4961*6D*+TXV	G*VC950915DXA*	55,000	16.60	12.10	50,900	39,200	56,000	4594935

See Notes on Page 22.

AHRI RATINGS (CONT.)

OUTDOOR UNIT	INDOOR UNITS		COOLING CAPACITY (BTU/H)				HEATING CAPACITY (BTU/H)				AHRI #	
	COILS/AIR HANDLERS	FURNACES	TOTAL	SENS.	SEER <sup>1</sup>	EER <sup>2</sup>	TOTAL	SENS. <sup>3</sup>	HI (47F)	HSPF <sup>4</sup>		LOW (17F)
ASZC18 0601B* (cont.)	CA *F4961 *6D*+TXV	A*VC950905DXA*	55,500	39,400	16.80	12.30	51,300	39,500	56,000	9.3	34,600	4431646
	CA *F4961 *6D*+TXV	A*VC80905CXA*	55,500	39,400	16.70	12.50	51,300	39,500	55,500	9.3	34,400	4431643
	CA *F4961 *6D*+TXV	G*E81155C**	55,500	39,400	16.60	12.20	51,300	39,500	56,000	9.2	34,800	4431650
	CA *F4961 *6D*+MBVC2000**+1A*+TXV	A*VC950905CXA*	56,500	40,100	17.10	12.60	52,300	40,300	56,500	9.4	35,000	4732370
	CSCF4860N6D*+TXV	A*VM961005DXA*	55,000	39,100	16.00	12.20	50,900	39,200	56,500	9.0	36,400	4770630
	CHPF4860D6D*+TXV	A*VM961005DXA*	55,000	39,100	16.40	12.10	50,900	39,200	56,000	9.2	34,600	4654924
	CA *F4961 *6D*+TXV	A*VM961005DXA*	55,500	39,400	16.30	12.20	51,300	39,500	56,000	9.2	34,800	4654903
	CSCF4860N6D*+TXV	G*VC81155CXA*	55,500	39,400	16.50	12.40	51,300	39,500	56,500	9.1	36,400	4770634
	CSCF4860N6D*+TXV	A*VC81155CXA*	55,500	39,400	16.50	12.40	51,300	39,500	56,500	9.1	36,400	4770629
	CSCF4860N6D*+TXV	A*VC80905CXA*	55,500	39,400	16.50	12.50	51,300	39,500	56,000	9.2	36,400	4770628
	CHPF4860D6D*+TXV	A*VM960805DXA*	55,000	39,100	16.80	12.20	50,900	39,200	56,000	9.3	34,600	4655145
	CSCF4860N6D*+TXV	G*VC80905CXA*	55,500	39,400	16.50	12.50	51,300	39,500	56,000	9.2	36,400	4770633
	CSCF4860N6D*+TXV	A*VC950905DXA*	55,500	39,400	16.50	12.40	51,300	39,500	56,500	9.2	36,400	4770631
	CSCF4860N6D*+TXV	A*VC951155DXA*	55,500	39,400	16.00	12.30	51,300	39,500	56,500	9.0	36,400	4770632
	CHPF4860D6D*+TXV	G*VC80805C*A*	55,500	39,400	16.50	12.00	51,300	39,500	55,500	9.3	34,200	4888274
	CHPF4860D6D*+TXV	G*VC81005C*A*	55,000	39,100	16.90	12.00	50,900	39,200	56,000	9.3	34,400	4888273
	CA *F4961 *6D*+TXV	G*VC81005C*A*	55,500	39,400	16.70	12.00	51,300	39,500	56,000	9.3	34,600	4888269
	CA *F4961 *6D*+TXV	G*VC80805C*A*	55,500	39,400	16.70	12.00	51,300	39,500	55,500	9.3	34,400	4888270
	CHPF4860D6D*+TXV	G*VC81005C*A*	55,000	39,100	16.90	12.00	50,900	39,200	56,000	9.3	34,400	4888275
	CA *F4961 *6D*+TXV	G*VC81005C*A*	55,500	39,400	16.70	12.00	51,300	39,500	56,000	9.3	34,600	4888271
CHPF4860D6D*+TXV	A*VC950905DXA*	55,000	39,100	16.80	12.20	50,900	39,200	56,000	9.3	34,600	4236606	
CHPF4860D6D*+TXV	G*VC80905CXA*	55,500	39,400	16.90	12.60	51,300	39,500	55,500	9.3	34,200	4236629	
CHPF4860D6D*+TXV	A*VC950905CXA*	55,000	39,100	16.40	12.00	50,900	39,200	56,000	9.2	34,800	4236603	
AEPF426016C*+TXV	G*E80905C**	56,000	39,800	17.00	12.50	51,800	39,900	56,000	9.5	34,600	4236601	
CA *F4961 *6D*+TXV	A*VC951155DXA*	55,500	39,400	16.70	12.60	51,300	39,500	55,500	9.3	34,400	4431649	
CA *F4961 *6D*+TXV	A*VM960805DXA*	55,500	39,400	16.30	12.20	51,300	39,500	56,000	9.2	34,800	4431648	
CA *F4961 *6D*+TXV	A*VM961155DXA*	55,000	39,100	16.60	12.10	50,900	39,200	56,000	9.2	34,800	4655134	
CHPF4860D6D*+TXV	A*VM961155DXA*	55,000	39,100	16.40	12.10	50,900	39,200	56,000	9.2	34,600	4654848	
CA *F4961 *6D*+TXV	G*VC80805C*A*	55,500	39,400	16.70	12.00	51,300	39,500	55,500	9.3	34,400	4888268	
CHPF4860D6D*+TXV	G*VC80805C*A*	55,500	39,400	16.50	12.00	51,300	39,500	55,500	9.3	34,200	4888272	

- Seasonal Energy Efficiency Ratio
- Energy Efficiency Ratio @ 80°F/ 67°F/ 95°F
- TVA Rating: BTU/h @ 75°F/ 63°F - 95°F
- HSPF = Heating Seasonal Performance Factor

NOTES

- Always check the S&R plate for electrical data on the unit being installed.
- When matching the outdoor unit to the indoor unit, use the piston supplied with the outdoor unit or that specified on the piston kit chart supplied with the indoor unit.
- EER - Order from Service Dept. Part No. B13707-38 or new Solid State Board B13707-35S. The Goodman Gas Furnace contains the EEP cooling time delay



## DIMENSIONS

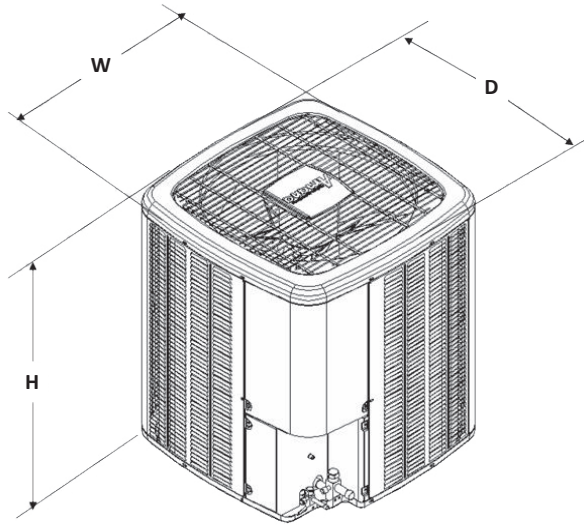

MODEL	W"	D"	H"
ASZC180361A	35½	35½	38¼
ASZC180481A	35½	35½	38¼
ASZC180601B	35½	35½	38¼

## ACCESSORIES

MODEL	DESCRIPTION	ASZC18 036	ASZC18 048	ASZC18 060
ABK-20	Anchor Bracket Kit <sup>0</sup>	X	X	X
B1141643 <sup>1</sup>	24V Transformer	X	X	X
CSR-U-1	Hard-start Kit	X		
CSR-U-2	Hard-start Kit	X	X	X
CSR-U-3	Hard-start Kit		X	X
FSK01A <sup>2</sup>	Freeze Protection Kit	X	X	X
OT18-60A <sup>3</sup>	Outdoor Thermostat/Lockout Thermostat	X	X	X
TX2N4 <sup>4</sup>	TXV Kit			
TX2N4A <sup>4</sup>	TXV Kit			
TX3N4 <sup>4</sup>	TXV Kit	X		
TX5N4 <sup>4</sup>	TXV Kit		X	X

<sup>0</sup> Contains 20 brackets; four brackets needed to anchor unit to pad

<sup>1</sup> Available in 24V legacy mode only. This feature is integrated in the communicating mode.

<sup>2</sup> Installed on indoor coil

<sup>3</sup> Available in 24V legacy mode only. This feature is integrated in the communicating mode. Required for heat pump applications where ambient temperature falls below 0 °F with 50% or higher relative humidity.

<sup>4</sup> Condensing units and heat pumps with reciprocating compressors require the use of start-assist components when used in conjunction with an indoor coil using a non-bleed thermal expansion valve refrigerant metering device or liquid line solenoid kit. The TXV should always be sized based on the tonnage of the outdoor unit.

